



# VCU

Virginia Commonwealth University  
VCU Scholars Compass

---

Theses and Dissertations

Graduate School

---

2005

## The Use of Computerized Dynamic Posturography to Assess the Balance in Individuals with Parkinson's Disease

Theresa Erin McGuirk  
*Virginia Commonwealth University*

Follow this and additional works at: <https://scholarscompass.vcu.edu/etd>



Part of the [Biomedical Engineering and Bioengineering Commons](#)

© The Author

---

Downloaded from

<https://scholarscompass.vcu.edu/etd/836>

This Thesis is brought to you for free and open access by the Graduate School at VCU Scholars Compass. It has been accepted for inclusion in Theses and Dissertations by an authorized administrator of VCU Scholars Compass. For more information, please contact [libcompass@vcu.edu](mailto:libcompass@vcu.edu).

© Theresa Erin McGuirk, 2005

All Rights Reserved

THE USE OF COMPUTERIZED DYNAMIC POSTUROGRAPHY TO ASSESS  
BALANCE IN INDIVIDUALS WITH PARKINSON'S DISEASE

A thesis submitted in partial fulfillment of the requirements for the degree of Master of  
Science of Biomedical Engineering at Virginia Commonwealth University.

by

THERESA ERIN MCGUIRK

Bachelor of Science in Mechanical Engineering, Virginia Polytechnic Institute and State  
University, 2002

Director: Dr. Peter S. Lum

Associate Professor, Department of Biomedical Engineering

Virginia Commonwealth University  
Richmond, Virginia  
December 2005

## Acknowledgement

The author wishes to thank several people. I would like to thank my family for their love and prayers as I complete this degree. I would like to thank my parents for their unending love and support, the Bennies and Rinas for being geese and Stephanie and Elizabeth for always being there for me. I would also like to thank Dr. Wetzel for his professional guidance, Dr. Pidcoe for teaching me to always ask 'Why?' and Dr. Qutubuddin for guiding me through all the issues of this topic, as well as the value of patient care. Last but not least, I would like to thank PADRECC for allowing me to use this subject for my thesis.

## Table of Contents

	Page
Acknowledgements.....	ii
Table of Contents.....	iii
List of Tables.....	vii
List of Figures.....	viii
Abstract.....	x
<b>Chapter</b>	
<b>1. Introduction.....</b>	<b>1</b>
<b>1.1. A Rational for this Study.....</b>	<b>2</b>
<b>1.2. Tools Currently Used to Measure Postural Instability of the PD Population.....</b>	<b>2</b>
<b>1.2.1. The Unified Parkinson’s Disease Rating Scale (UPDRS).....</b>	<b>3</b>
<b>1.2.1.1. UPDRS Validity.....</b>	<b>4</b>
<b>1.2.1.2. UPDRS Reliability.....</b>	<b>4</b>
<b>1.2.2. The Berg Balance Scale (BBS).....</b>	<b>4</b>
<b>1.2.2.1. BBS Validity.....</b>	<b>5</b>
<b>1.2.2.2. BBS Reliability.....</b>	<b>5</b>
<b>1.2.3. Computerized Dynamic Posturography (CDP).....</b>	<b>6</b>
<b>1.2.3.1. CDP Validity.....</b>	<b>7</b>
<b>1.2.3.2. CDP Reliability.....</b>	<b>8</b>

1.3. Objectives for this Study.....	8
2. The Smart Balance Master System.....	9
2.1. NeuroCom International, Inc.....	10
2.2. Specifications of Electrical and Mechanical Components.....	10
2.3. Calculation of Surface Forceplate Measurements.....	13
2.4. Calculation of Center of Gravity Measurements.....	14
2.5. Calculation of COG Sway Angle.....	15
3. Data Collection Methods.....	16
3.1. Testing Location and Protocol.....	16
3.2. Subject Examination.....	17
3.3. Subject Testing Preparation Protocol.....	18
3.4. Subject Testing with the Smart Balance Master.....	20
3.4.1. Sensory Organization Test (SOT).....	21
3.4.2. Adaptation Test (ADT).....	24
3.4.3. Limits of Stability Test (LOS).....	26
3.5. Completion of Subject Testing.....	27
4. Data Analysis Methods.....	28
4.1. Data Variables.....	28
4.2. Adjusting the NeuroCom Healthy Population Data.....	29
4.3. Data Population Characteristics.....	31
4.3.1. Determining Normal Distribution of Population Data.....	31
4.3.2. F-Test: Equal Variance Test.....	32

4.4. <i>T</i> -Test: Significantly Different Population Means Test.....	33
4.4.1. <i>P</i> -Value Test.....	35
4.5. Correlation Analysis .....	35
5. Results.....	36
5.1. Demographic Data .....	36
5.2. Clinical Data .....	36
5.3. Comparative Population Means Data .....	36
5.4. Correlational Data.....	38
6. Discussion .....	39
6.1. Describing the Balance Deficits of the PD Patient.....	39
6.1.1. The Sensory Organization Test (SOT) .....	40
6.1.2. The Adaptation Test (ADT).....	41
6.1.3. The Limits of Stability Test (LOS).....	41
6.2. Interpreting Abnormal SBM Scores for a PD Patient.....	42
6.2.1. The Implications of an Abnormal SOT Score for a PD Patient.....	43
6.2.2. The Implications of an Abnormal ADT Score for a PD Patient.....	43
6.2.3. The Implications of an Abnormal LOS Score for a PD Patient.....	44
6.3. Correlation Between the SBM Subscores and UPDRS and BBS Scores ....	45
6.4. Addressing the Design Specifications of NeuroCom’s SBM System .....	46
6.4.1. The Testing Protocol of the Smart Balance Master System .....	46
6.4.2. The Implications of Instrument Filter Use on PD Subject Response Time .....	47

	vi
7. Conclusions.....	48
Literature Cited .....	49
Appendices	
<b>A. Unified Parkinson’s Disease Rating Scale: Motor Section.....</b>	<b>68</b>
<b>B. Berg Balance Scale .....</b>	<b>71</b>
<b>C. IRB Consent Form .....</b>	<b>75</b>
<b>D. Sensory Organization Test Printout Example.....</b>	<b>82</b>
<b>E. Adaptation Test Printout Example.....</b>	<b>84</b>
<b>F. Limits of Stability Test (LOS) Printout Example.....</b>	<b>86</b>
<b>G. Parkinson’s Disease Population Raw Data.....</b>	<b>88</b>
<b>H. NeuroCom Healthy Population Mean and SD Data .....</b>	<b>91</b>
<b>I. Adjusted NeuroCom Healthy Population Mean and SD Data.....</b>	<b>92</b>
<b>J. Histograms &amp; P-P Plots of PD Population .....</b>	<b>93</b>
<b>K. Sample Calculations.....</b>	<b>100</b>
<b>K.1. Adjusting NeuroCom Healthy Population Calculation .....</b>	<b>100</b>
<b>K.2. Skewness and Kurtosis Value Calculation .....</b>	<b>101</b>
<b>K.3. Equal Variance Calculation: F-test.....</b>	<b>101</b>
<b>K.4. Significant Difference Population Means Calculation: <i>t</i>-test .....</b>	<b>102</b>
Vita.....	104



## List of Tables

	Page
<b>Table 1:</b> Electrical characteristics of forceplate transducers.....	11
<b>Table 2:</b> Performance characteristics of two servomotors. ....	12
<b>Table 3:</b> Description of the six SOT tests .....	22
<b>Table 4:</b> Smart Balance Master tests the PD population is expected to score significantly lower in, when compared to the healthy population. ....	30
<b>Table 5:</b> Smart Balance Master tests the PD population is expected to score significantly higher in, when compared to the healthy population. ....	30
<b>Table 6:</b> Skewness and Kurtosis tests: normal distribution results.....	33
<b>Table 7:</b> F-Test: unequal variance results. ....	34
<b>Table 8:</b> Demographic and clinical variables of study subjects.....	38
<b>Table 9:</b> Significant difference of Smart Balance Master test scores, comparing PD population and NeuroCom healthy population: Part 1. ....	39
<b>Table 10:</b> Significant difference of Smart Balance Master test scores, comparing PD population and NeuroCom healthy population: Part 2. ....	39
<b>Table 11:</b> Pearson's correlation of CDP measurements to UPDRS and BBS. ....	40
<b>Table H.1:</b> SOT NeuroCom healthy population means and standard deviations. ....	93
<b>Table H.2:</b> ADT NeuroCom healthy population means and standard deviations. ....	93
<b>Table H.3:</b> LOS NeuroCom healthy population means and standard deviations. ....	93

## List of Figures

	Page
<b>Figure 1:</b> The Smart Balance Master system .....	9
<b>Figure 2:</b> Moving surface and moving surround .....	10
<b>Figure 3:</b> Dual forceplate configuration.....	11
<b>Figure 4:</b> Flowchart representing the Smart Balance Master system collecting data.....	12
<b>Figure 5:</b> Illustration of center of gravity and center of foot placement.....	15
<b>Figure 6:</b> Geometric relationship between $\theta$ and $P_y$ .....	15
<b>Figure 7:</b> Safety harness front and back.....	19
<b>Figure 8:</b> Subject's feet positioned on forceplate. ....	20
<b>Figure 9:</b> The 6 sensory positions of SOT protocol.....	22
<b>Figure 10:</b> Toes up and toes down rotations .....	25
<b>Figure 11:</b> LOS screen.....	26
<b>Figure J.1:</b> UPDRS histogram and P-P plot of PD data .....	95
<b>Figure J.2:</b> BBS histogram and P-P plot of PD data .....	95
<b>Figure J.3:</b> SOT Composite histogram and P-P plot of PD data .....	96
<b>Figure J.4:</b> SOT Somatosensory histogram and P-P plot of PD data.....	96
<b>Figure J.5:</b> SOT Visual histogram and P-P plot of PD data .....	97
<b>Figure J.6:</b> SOT Vestibular histogram and P-P plot of PD data.....	97
<b>Figure J.7:</b> SOT Preferential histogram and P-P plot of PD data.....	98

<b>Figure J.8:</b> ADT Toes UP (5 <sup>th</sup> attempt) histogram and P-P plot of PD data .....	98
<b>Figure J.9:</b> ADT Toes DOWN (5 <sup>th</sup> attempt) histogram and P-P plot of PD data.....	99
<b>Figure J.10:</b> LOS Reaction Time histogram and P-P plot of PD data.....	99
<b>Figure J.11:</b> LOS Movement Velocity histogram and P-P plot of PD data .....	100
<b>Figure J.12:</b> LOS Endpoint Excursion histogram and P-P plot of PD data.....	100
<b>Figure J.13:</b> LOS Maximum Excursion histogram and P-P plot of PD data.....	101
<b>Figure J.14:</b> LOS Directional Control histogram and P-P plot of PD .....	101

## **Abstract**

### **THE USE OF COMPUTERIZED DYNAMIC POSTUROGRAPHY TO ASSESS THE BALANCE IN INDIVIDUALS WITH PARKINSON'S DISEASE**

By Theresa Erin McGuirk, BS

A thesis submitted in partial fulfillment of the requirements for the degree of Master of  
Science of Biomedical Engineering at Virginia Commonwealth University.

Virginia Commonwealth University, 2005

Major Director: Dr. Peter S. Lum  
Associate Professor, Department of Biomedical Engineering

Postural instability is one of the hallmarks of Parkinson's disease (PD), currently evaluated using several subjective tools. However, the nature and degree of the resulting balance deficit is not well specified by these tools. Computerized dynamic posturography (CDP) provides an objective assessment by isolating and quantifying sensory and motor contributions to balance control. The purpose of this study was to compare balance in individuals with PD to a control group using CDP (NeuroCom Smart Balance Master<sup>®</sup> system). Testing took place at the Southeast Parkinson's disease Research Education and Clinical Center (PADRECC), an interdisciplinary center of excellence for people with PD within a Veterans Affairs Medical Center. The 51 PD patients (mean age =  $72.18 \pm 6.98$  years;) were compared to 55 age-matched controls

supplied by the CDP manufacturer. Subjects were assessed with three test scales defined by the Smart Balance Master<sup>®</sup> system: Sensory Organization Test (SOT), Adaptation Test (ADT), and Limits of Stability Test (LOS). All PD population CDP scores were significantly different ( $\alpha=0.05$ ) than those of a healthy population, except for the SOT Somatosensory subscale ( $p=0.28$ ), LOS Directional Control subscale ( $p=0.08$ ), ADT Toes Up subscale ( $p=0.16$ ) and ADT Toes Down subscale ( $p=0.23$ ). The Smart Balance Master<sup>®</sup> system's LOS Movement Velocity, Endpoint Excursion, Maximum Excursion, and Reaction Time subscores and the SOT Composite, Visual, and Vestibular subscores uniquely describe the varying symptoms of the disease. These disease specific abnormalities may provide insight into focused treatment intervention strategies.

## CHAPTER 1: INTRODUCTION

Parkinson's disease (PD) is a progressive neurodegenerative movement disorder associated with a loss of dopaminergic nigrostriatal neurons. An estimated 1.5 million Americans are affected by PD with 20 new cases per 100,000 people per year.<sup>70</sup> The four primary symptoms of PD are tremor, rigidity, bradykinesia, and postural instability. Postural instability usually occurs in the late stages of the disease, as a result of increased extremity and truncal tone, motor incoordination, and dystonomia. More than 35% of people with advanced PD experience falls and 18% sustain fractures as a result of these falls.<sup>86</sup>

There is no cure for PD, but symptoms can be managed using medicine, surgery and rehabilitative physical therapy. Once PD is diagnosed, the gold standard of present therapy is the drug levodopa (L-3,4-dihydroxyphenylalanine). L-dopa is used by nerve cells in the brain to make dopamine. L-dopa is effective in approximately 75% of patients diagnosed with PD. Other medications include Bromocriptine, Selegiline, Anticholinergics, and Amantadine. When medication is not found to be effective, surgery is sometimes used to reduce PD symptoms. Procedures such as cryothalamotomy and thalamic stimulation are used to affect the area found to produce tremor in the body.<sup>69</sup>

it can improve body strength and balance helping PD patients overcome gait problems. Just as importantly, exercise gives the PD patient a sense of accomplishment and freedom

### 1.1. A Rationale for this Study.

Postural instability is one of the hallmarks of Parkinson's disease, even in the early stages of presentation. The inability to maintain balance predisposes affected PD patients to a loss of equilibrium and falls leading to more disability.<sup>9,47</sup> Researchers have reported that 38-68% of individuals with PD had fallen in the recent past and 13% fell more than once a week.<sup>49,97</sup> Prior studies have found that balance impairment is a primary risk factor in the occurrence of falls.<sup>11,15,60,66,80,88,96</sup> Further, PD patients walk with significantly reduced speed and mean step length compared to control subjects.<sup>12,75</sup> Based on these studies, the accurate assessment of postural instability is a significant issue for the PD population. Interestingly, despite the high prevalence of PD and the severity of the functional limitations resulting from balance deficits, there is little agreement among health professionals about the most appropriate tools with which to quantify this impairment.

### 1.2. Tools Currently Used to Measure Postural Instability in the PD Population.

There are several measurement tools used in clinics as well as research when evaluating a PD patient.

The retropulsion test, which measures a patient's ability to recover equilibrium after sudden pulling backward on the shoulders, has been suggested as the most valid test for postural stability in Parkinson's disease.<sup>10,90</sup> However, this test is subjective and no standard method of administration exists.

The Hoehn and Yahr Rating Scale<sup>28,63,78</sup> and the modified Schwab and England Capacity for Daily Living Scale<sup>28,44,33</sup> are also frequently used to evaluate the impact of Parkinson's disease, but do not directly assess postural instability.

Two current tools are discussed in detail below: The Unified Parkinson's Disease Rating Scale (UPDRS) and the Berg Balance Scale (BBS). While these methods of measuring functional impairment in Parkinson's disease exist, at present no 'gold standard' exists for assessing postural instability.

#### 1.2.1. The Unified Parkinson's Disease Rating Scale (UPDRS).

The UPDRS is currently the most widely accepted scale for measuring the components of PD.<sup>28,32,33</sup> It was developed in 1987 by combining the PD rating scales available at the time.<sup>28</sup> The UPDRS is used in clinical research and drug trials to follow the longitudinal course of PD.<sup>28,43,58</sup>

The UPDRS is divided into four subscales, including 1) Mentation, Behavior, and Mood, 2) Activities of Daily Living, 3) Motor, and 4) Complications of Therapy [APPENDIX A]. In its entirety it provides an overall assessment that quantifies all the motor and behavioral aspects of the disease. The motor component (UPDRS-III) has been used to assess postural instability.<sup>28,43,72,73,79,87</sup> UPDRS-III evaluates 14 items with 27



distinct functions. Each item is scored on a scale of 0 to 4. A total of 108 points is possible, with 108 representing maximum (or total) disability and 0 representing no disability.

#### 1.2.1.1. UPDRS Validity.

The UPDRS is one of the most evaluated, valid and reliable scales currently available.<sup>78</sup> Several studies have investigated the structure and measurement capabilities of the UPDRS and have found a high inter-rater consistency.<sup>61,87</sup> A videotape of the UPDRS motor exams has also been found to be useful when diagnosing PD, contributing to the validity of the scale.<sup>34,57</sup>

#### 1.2.1.2. UPDRS Reliability.

The inter-rater<sup>55,85</sup> and intra-rater<sup>55,78</sup> (test-retest) reliability of the UPDRS scale has been examined and shown to be a highly reliable measurement of PD. Intra-test reliability of UPDRSm has also been studied and found to possess a high test-retest reliability.<sup>55,64</sup>

#### 1.2.2. The Berg Balance Scale (BBS).

The Berg Balance Scale is an objective measure of balance abilities. It has been used to identify and evaluate balance impairment.<sup>2,41,51,52,53,59,72,73,80,81,83</sup> The BBS has also been used to validate other scales including the Activities-specific Balance Confidence (ABC) scale,<sup>13</sup> the Lower Extremity Motor Coordination Test (LEMOCOT),<sup>23</sup> the

Dynamic Gait Index (DGI),<sup>94</sup> and several functional balance tests used on post-stroke patients.<sup>89</sup>

The BBS is a detailed balance examination that evaluates 14 tasks common to everyday life.<sup>3</sup> The items test a subject's ability to maintain positions or movements of increasing difficulty by diminishing the base of support from sitting to standing to single-leg stance [APPENDIX B]. One's ability to change positions is also assessed. Each item is scored on a scale of 0 to 4. A total of 56 points is possible, with 0 representing maximum (or total) disability and 56 representing no disability.

#### 1.2.2.1. BBS Validity.

The BBS has recently been demonstrated to be a valid measure of balance and disease severity in PD as well.<sup>4,5,77</sup> Although the scale has been validated numerous times, one recent study performed on a chronic stroke population found the BBS to be unclear and recommend caution when interpreting BBS scores. It is suggested clinicians who want to determine fall risk look at reactive balance as opposed to walking balance.<sup>4</sup> Improvements on the condensed item-rating categories of the BBS have also been suggested.<sup>50,98</sup>

#### 1.2.2.2. BBS Reliability.

The inter-rater and intra-rater (test-retest) reliability of the BBS scale has been examined and shown to be a reliable measurement of PD.<sup>53,82</sup>

### 1.2.3. Computerized Dynamic Posturography (CDP)

Computerized dynamic posturography (CDP) is defined by the American Academy of Otolaryngology-Head and Neck Surgery and the American Academy of Neurology as a system which “isolates and quantifies sensory and motor contributions to balance control and assesses sensorimotor integration in people with normal and abnormal sensorimotor skills.”<sup>6</sup> In 2000, the American Medical Association added posturography as a criteria method for documentation of disability and impairment.<sup>21</sup>

CDP systems were designed to evaluate and train static and dynamic balance performance.<sup>56,68,91</sup> The designs, once validated, provide an objective assessment of the sensory and voluntary motor control of balance with visual biofeedback on either a stable or unstable support surface and in a stable or dynamic visual environment.<sup>67</sup> CDP is the only method validated by controlled research studies to isolate the functional contributions of vestibular inputs, visual inputs, somatosensory inputs, central integrating mechanisms, and neuromuscular system outputs for postural and balance control.<sup>8,27</sup> CDP systems have allowed clinicians to objectively measure the postural components of balance<sup>1,3,7,14,15,16,17,18,19,22,26,29,36,37,39,40,42,43,46,65,92,95</sup> and are able to differentiate between elderly fallers and non-fallers.<sup>93</sup>

CDP is more effective than standard diagnostic tests in differentiating between PD and PSP in their early stages.<sup>74</sup> Early differentiation improves outcome, because PSP patients do not respond well to dopaminergic medication. In its early stage, PSP is often mistaken for PD. CDP (NeuroCom’s<sup>a</sup> EquiTest system) has been shown to be the only

test that quantified differences in sensory impairments among idiopathic bilateral vestibular loss (BVL) patients.<sup>84</sup>

CDP (NeuroCom's<sup>®</sup> EquiTest system) has demonstrated the ability to describe the neuro-otological abnormalities associated with dizziness and was the most sensitive diagnostic test for identifying abnormality in dizzy patient population.<sup>99</sup>

CDP has also shown the ability to detect malingering; the false or exaggeration of a physical or mental disease in order to obtain money, drugs, or evade duty or criminal responsibility.<sup>34</sup> The systems have been used to document posturographic evidence on nonorganic sway patterns; identifying patients exaggerating sway from those with balance disorders for which treatment was medically necessary.<sup>30,31</sup>

CDP has also demonstrated the ability to identify athletes with poor ankle strategy, effectively predicting those athletes likely to suffer ankle sprains during the course of a season.<sup>62</sup>

CDP can play an important role of the function evaluation and management of PD patients and offers the opportunity to more objectively evaluate the nature and degree of postural instability in PD.

#### 1.2.3.1. CDP Validity.

Controlled research studies have shown CDP to be the only method validated to isolate vestibular inputs, visual inputs, somatosensory inputs, central integrating mechanisms and neuromuscular system outputs.<sup>6,7,81</sup>

### 1.2.3.2. CDP Reliability.

The test-retest reliability of CDP has been measured on several different systems such as NeuroCom's<sup>a</sup> ProBalance Master<sup>25</sup> and NeuroCom's<sup>a</sup> Smart Balance Master<sup>54</sup> systems. The measurements evaluated on these systems have shown reliability<sup>20</sup> although it is suggested that clinicians use caution when interpreting CDP scores.

### 1.3. Objectives for this Study.

This study was designed to identify the clinical utility and validity of computerized dynamic posturography, using the NeuroCom<sup>a</sup> Smart Balance Master system as a tool used to quantify a balance deficit. There are two objectives for this study:

- 1) Determine whether PD patient population scores produced by the Smart Balance Master system are significantly different than those of a typical healthy population, demonstrating that the Smart Balance Master® (SBM) system is capable of describing the balance characteristics of a typical idiopathic PD patient population.
- 2) Determine which SBM scores have a strong correlation with currently accepted measures of postural instability among the PD patient population: the UPDRS and BBS.

## CHAPTER 2: THE SMART BALANCE MASTER<sup>®</sup> SYSTEM

The Smart Balance Master<sup>®</sup> (SBM) system is a computerized dynamic posturography (CDP) system designed to assess a patient's balance or provide balance-retaining therapy, (Figure 1). The system provides visual feedback to a patient on either a stable or unstable support surface and in a stable or dynamic visual environment, (Figure 2). Version 8.2 was used in this study.



**Figure 1.** The Smart Balance Master system.

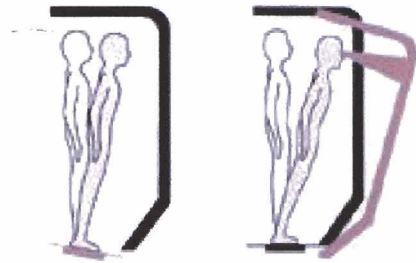

**Figure 2.** Moving surface and moving surround. (Courtesy of NeuroCom® International, Inc.)

### 2.1. NeuroCom International, Inc.

The Smart Balance Master® (SBM) system was designed by NeuroCom International, Inc.<sup>a</sup>, a company founded by Lewis Nashner in 1984. The company works in the development of computerized tools for the assessment and rehabilitation of patients with balance and mobility disorders.

NeuroCom International, Inc.  
9570 SE Lawnfield Road  
Clackamas, Oregon 97015  
1-800-767-6744 Tel  
1-500-653-1991 Fax  
[www.onbalance.com](http://www.onbalance.com)

### 2.2. Specifications of Electrical and Mechanical Components.

The SBM system utilizes a dual forceplate, (Figure 3). The forceplate consists of two 9" x 18" footplates which are connected by a pin joint. The footplates are supported by four strain gauges, which are mounted on a supporting center plate. A fifth transducer is attached to the center plate directly beneath the pin joint.

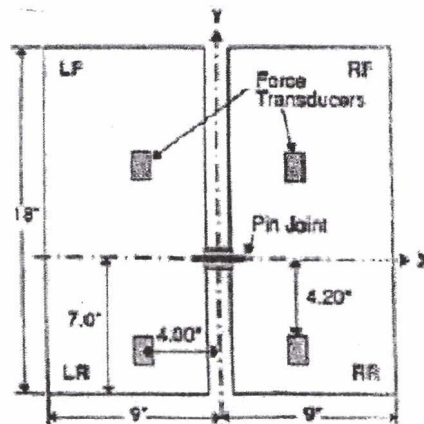

Figure 3. Dual forceplate configuration. (Courtesy of NeuroCom<sup>®</sup> International, Inc.)

The five strain gauges transduce force. The center strain gauge, located directly below the pin joint measures shear forces along the y-axis. The y-axis is considered the plane parallel to the floor. The other four strain gauges measure vertical force applied directly to the forceplate. The pin joint, mentioned earlier, is used to allow the vertical forces to be measured separately on the right and left footplates. Each transducer requires a separate differential amplifier to condition the outputs. The electrical characteristics of the forceplate transducers are listed in Table 1.

**Table 1.** Electrical characteristics of forceplate transducers.

Sensitivity	25 mV/lb (55V/kg)
Calibration	
Gain	0.1 lb (45 g)
Zero	0.1 lb (45 g)
Gain Temperature Coefficient	0.01 lb/°C (4.5 g/°C)
Gain Zero Coefficient	0.01 lb/°C (4.5 g/°C)
Linearity	0.05 lb (2.3 g)
Output Range	175 lb (79.4 kg)



The forceplate is moved by two long-life direct-current instrumentation servomotors in response to command signals from the computer, (Figure 4).

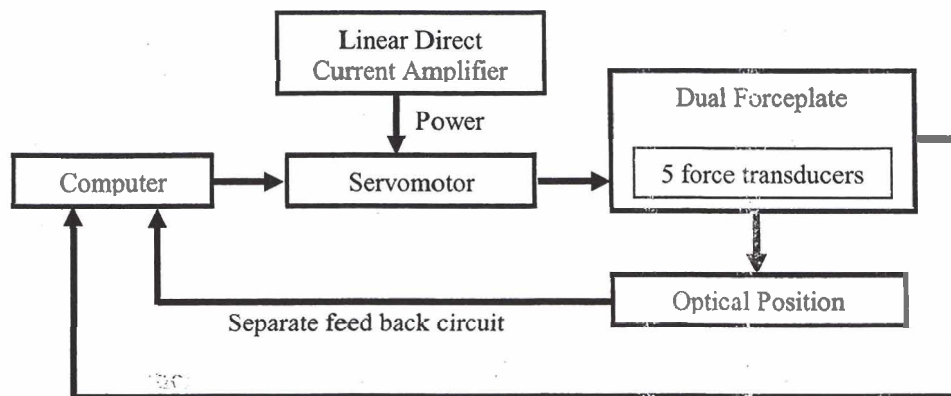

Figure 4. Flowchart representing the Smart Balance Master system collecting and recording data.

Ball bearing gears provide approximately 95 percent of the motors' power to the forceplate surface rotations. The gear ratio for the two servomotors to forceplate turns is 212:1. The gear ratio for the two servomotors to the visual surround turns is 840:1. Each servomotor is powered by a separate linear direct current amplifier. Rotational positions of the servomotors are measured by optical position encoders and controlled by separate feedback circuits. The performance characteristics of the servomotors are listed in Table

2.

Table 2. Performance characteristics of the two servomotors.

Tilt	
Output sensitivity	1 deg/volt
Range	±10 deg
Maximum velocity	50 deg/sec (at 4 deg rotate)
Time to maximum velocity	50 msec
Maximum torque (static) 1	200 ft-lb (271 J)
Visual surround tilt	
Output sensitivity	1 deg/volt
Range	±10 deg
Maximum velocity	15 deg/sec

The data is collected at a sampling rate of 100 Hz and recorded using a 2<sup>nd</sup> order Butterworth filter with a 12-bit resolution. The cutoff frequency is 0.85 Hz.

### 2.3. Calculation of Surface Forceplate Measurements.

The SBM system measures and calculates five different forces, which the patient exerts on the dual forceplate. These five forces are the total vertical force ( $F_v$ ), total horizontal force ( $F_h$ ), lateral center of vertical force ( $P_x$ ), left AP y-axis center of vertical force ( $P_{yL}$ ), and right AP y-axis center of vertical force ( $P_{yR}$ ).

$F_v$  is the subject's weight. It is measured by the four corner transducers (described previously) and then calculated by summing them together. The corner transducers are described as RF (right front transducer), RR (right rear transducer), LF (left front transducer) and LR (left rear transducer).

$$F_v = RF + RR + LF + LR \quad \text{Equation 1.}$$

$F_h$  is measured directly by the center force transducer.

The SBM system creates a hypothetical point on the forceplate. This point is a vertical projection of the patient's center of gravity onto the dual forceplate at any given instant in time.  $P_x$  is the distance between this hypothetical point and the y-axis. There are 4.00 inches between each of the force transducers and the y-axis.

$$P_x = \frac{(RF + RR) - (LF + LR)}{RF + RR + LF + LR} * 4.00 \quad \text{Equation 2.}$$

$P_y$  is the distance between the hypothetical point and the x-axis. There are 4.20 inches between each of the force transducers and the x-axis.

$$P_y = \frac{[(LF + RF) - LR + RR]}{LF + RF + LR + RR} * 4.20$$

*Equation 3.*

The SBM system calculates the components of  $P_y$ .  $P_{yL}$  is the left component of the distance between the hypothetical point and the x-axis.

$$P_{yL} = \frac{LF - LR}{LF + LR} * 4.20$$

*Equation 4.*

$P_{yR}$  is the right component of the distance between the hypothetical point and the x-axis.

$$P_{yR} = \frac{RF - RR}{RF + RR} * 4.20$$

*Equation 5.*

#### 2.4. Calculation of Center of Gravity Measurements.

To calculate the center of gravity (COG) of the subject, the following references were used, (Figure 5). Experimentally, in the upright stance, a subject's COG is positioned at a height 55% of the total height of the subject and 14% of the foot length in front of the medial malleolus bone in the ankle joint. This positions the COG at an inclined angle of 2.3° forward from the vertical line passing through the ankle joint.

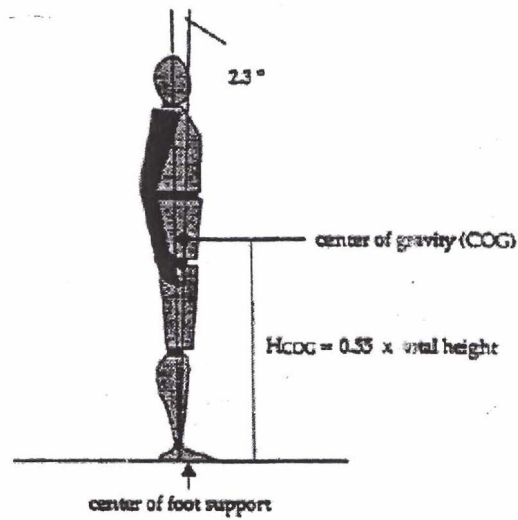

**Figure 5.** Illustration of center of gravity and center of foot placement. (Courtesy of NeuroCom<sup>®</sup> International, Inc.)

### 2.5. Calculation of the COG Sway Angle.

The SBM system software computes  $\theta$ , (Figure 6), using values of  $P_{COG}$  and  $H_{COG}$ , (Equation 6).

$$\theta = \arcsin\left(\frac{P_{COG}}{H_{COG}}\right) - 2.3^\circ$$

*Equation 6.*

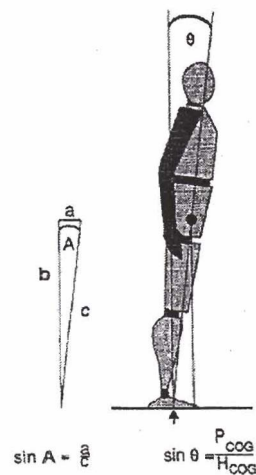

**Figure 6.** Geometric relationship between  $\theta$  and  $P_y$ . (Courtesy of NeuroCom<sup>®</sup> International, Inc.)

## CHAPTER 3: DATA COLLECTION METHODS

The author began data collection by recruiting subjects for this study from the PADRECC patient list. Admissible subjects must have been diagnosed with Parkinson's disease, be able to stand without the use of an assistive device and not suffer from dementia. In general, this limited testable subjects to patients with mild Parkinson's disease. The diagnosis of PD was confirmed by the PADRECC neurologist (i.e., appropriate clinical findings, and confirmed responsiveness to dopamine or dopamine-agonists), and all participants were ambulatory without any assistive device or physical assistance during their initial clinical evaluation. Each subject was either called at home or approached while already visiting PADRECC for a previously scheduled appointment. Subjects or caretakers were presented with the purpose of the balance study as well as what would be expected of the subject before, during and after testing along with any risks involved. Interested participants were scheduled to come in for testing and given a study card with the date, time and location of the testing as well as contact information of the author.

### 3.1. Testing Location and Protocol.

The Hunter Holmes McGuire Veterans Affairs Medical Center in Richmond, Virginia, is one of six Veterans Health System centers of excellence for the treatment of

PD. Patients referred to the Parkinson's Disease Research, Education, and Clinical Center (PADRECC) at this facility underwent a comprehensive interdisciplinary evaluation that included examinations by a neurologist, neuropsychologist, trained movement disorders nurse, and psychiatrist. Eligible participants were evaluated by PADRECC clinicians between September, 2004 and August, 2005. The only ambulatory subjects excluded from participation were those ascertained to be cognitively impaired to the point of being unable to understand procedural instruction and safely complete the testing protocol. Demographic data was collected from patients' medical records, clinical interviews, and a directed physical examination. A signed consent form, consistent with Internal Review Board processes, was obtained, [APPENDIX C].

### 3.2. Subject Examination.

The examination of each subject began by presenting each subject with a consent form consistent with Internal Review Board (IRB). The purpose and procedure of the study as well as what would be expected of the subject during testing and any risks involved were reiterated. The consent form was then signed.

An objective evaluation of the subject's balance was then taken to determine motor functioning, stage of disease, and daily living skills. The instruments used were the UPDRS motor section (UPDRS-III) and the BBS. These scales are described in detail in sections 1.2.1 and 1.2.2, [APPENDIX A and APPENDIX B, respectively].

If PADRECC did not already have scores from the subject dated within three months of the date of testing, they were obtained during the examination. The author

performed the BBS and requested the service of a trained clinician to obtain the UPDRS score.

### 3.3: Subject Testing Preparation Protocol.

The demographic data of each subject including the subject's age and height were entered into the Smart Balance Master<sup>®</sup> (SBM) system computer. Name and the last four digits of the social security number were also recorded into the system for future reference. Subjects were asked to remove socks and shoes. Height was measured by asking the patient to stand with his/her back to a wall where a measurement device is located.

A common physical constraint of PD is a slouch of the back. The height of the subject with slouch was measured. This slouch does affect the placement of the center of gravity of the subject, moving it forward. This may have some affect on the validness of using a COG calculation as opposed to using center of pressure calculation.

The patient was then fitted with a safety harness, (Figure 7), which connects two suspension straps extending down from an overhead bar. The harness and suspension system are used to help prevent falls if the patient loses balance. Three harnesses were provided with the SBM system; small (S), medium (M) and large (L). Harness size was determined based on the subject's height and girth. The harness was fitted to be comfortable, but snug.

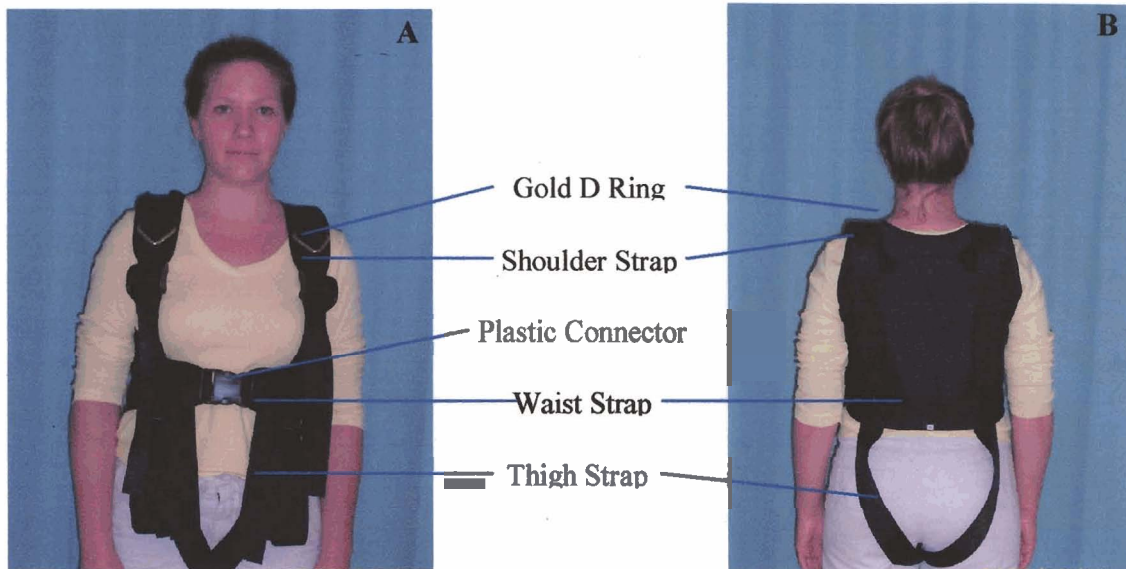

**Figure 7.** Safety harness front (A) and back (B).

The subject was then assisted into the SBM, stepping onto the forceplate. The subject faced the visual surround during testing. As soon as the subject was inside the SBM, the safety harness was attached to the suspension straps, (Figure 1). The straps were then adjusted to allow for subject movement from side to side, but could still safely break a fall, should the subject lose balance.

The subject's feet were then positioned on the forceplate by the author, (Figure 8). The medial malleolus of each foot was centered directly over a thick line on the dual forceplate positioned perpendicular to the subject. The lateral calcaneus was positioned according to the subject's height. The forceplate is marked with lines named 'S', 'M' and 'T' where

S = Short 30-55 inches/76-140 cm  
M = Medium 56-65 inches/141-165 cm  
T = Tall 66-80 inches/166-203 cm



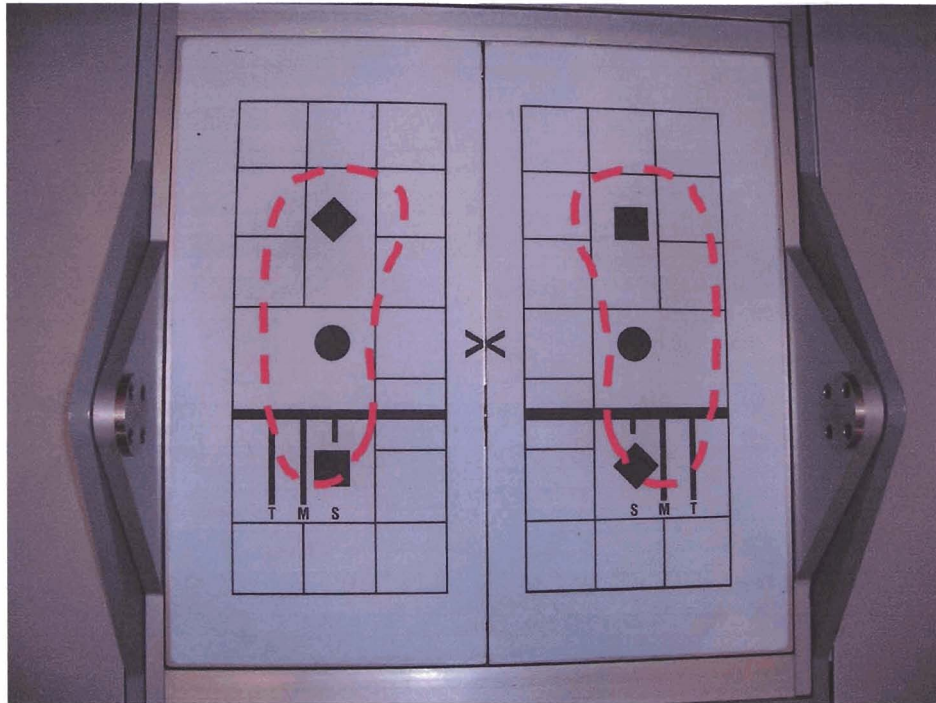

**Figure 8.** Subject's feet positioned on forceplate.

Once the patient was properly positioned and comfortable, tests utilizing the SBM may begin.

#### 3.4. Subject Testing with the Smart Balance Master.

Testing involved examination and data collection, with a time span of approximately forty-five minutes to one hour, depending on the subject. Before testing began, each subject was informed that breaks would be permitted as needed during testing. Subjects were also reminded of the restraining harness designed to provide support and prevent a fall in the chance the subject did lose balance. Subjects were advised to stand as relaxed and still as possible during each test, and to stand as close to vertical as possible. The system was then prepped by the author for the first test.

Three CDP assessment tests were used to analyze the balance capabilities of the subjects; the Sensory Organization Test (SOT), the Adaptation Test (ADT), and the Limits of Stability Test (LOS).<sup>71</sup> These three tests are described in detail below.

#### 3.4.1. The Sensory Organization Test (SOT).

The SOT is designed to assess a patient's use of the three sensory systems that contribute to balance and identify any abnormalities in the systems. These three sensory systems are the somatosensory system, visual system and vestibular system. The SOT protocol is comprised of six conditions in which the somatosensory and visual environments are systematically altered, as described in Table 3, (Figure 9). The patient's responses to these environmental changes are measured and recorded. The environment is altered by systematically eliminating information normally delivered to the patient's eyes, feet and joints. The SBM handbook refers to this technique as calibrated "sway-referencing."<sup>71</sup> Sway-referencing allows the forceplate and/or visual surround to tilt, following the patient's anteroposterior body sway. Sway-referencing, combined with asking the patient to either open or close the eyes creates sensory conflict situations for the subject and isolates vestibular balance control, as well as the adaptive responses of the central nervous system.

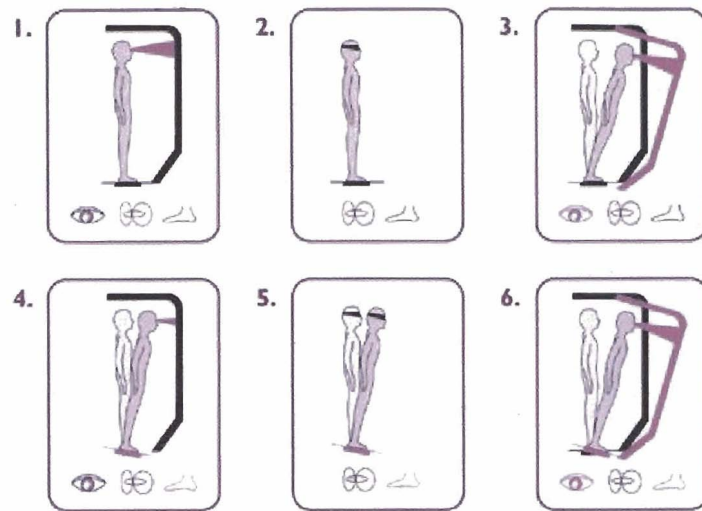

Sensory Organization Test

Figure 9. The 6 sensory conditions of SOT protocol. (Courtesy of NeuroCom® International, Inc.)

Table 3. Description of the six SOT tasks.

SOT Tasks	Condition Description
Condition 1	Eyes open, surround and platform stable
Condition 2	Eyes closed, surround and platform stable
Condition 3	Eyes open, sway-referenced surround
Condition 4	Eyes open, sway-referenced platform
Condition 5	Eyes closed, sway-referenced platform
Condition 6	Eyes open, sway-referenced surround and platform, measured over three trials each

A printout of this assessment was produced by the computer, [APPENDIX D].

The SOT Comprehensive Report provides four types of analysis: equilibrium score, sensory analysis, strategy analysis and center of gravity alignment.

The equilibrium score quantifies the Center of Gravity (COG) sway or postural stability under each of the three trials for each of the six sensory conditions. The composite equilibrium score is the weighted average of the scored of all sensory conditions. It is designed to measure the overall level of performance.

The sensory analysis ratios are used in combination with the equilibrium score to identify specific impairments of the individual's sensory system. The four ratios calculated are: Somatosensory (SOM), Visual (VIS), Vestibular (VEST) and Preferential (PREF), (Equations 7-10).

$$\text{SomatosensoryRatio} = \frac{\text{Condition2}}{\text{Condition1}} \quad \text{Equation 7.}$$

$$\text{VisualRatio} = \frac{\text{Condition4}}{\text{Condition1}} \quad \text{Equation 8.}$$

$$\text{VestibularRatio} = \frac{\text{Condition5}}{\text{Condition1}} \quad \text{Equation 9.}$$

$$\text{Pr eferentialRatio} = \frac{\text{Condition3} + 6}{\text{Condition2} + 5} \quad \text{Equation 10.}$$

Strategy analysis and center of gravity (COG) alignment are also calculated by the system, but were not used as analysis techniques for this study. Strategy analysis calculates the relative movement of the body about the ankle and hips. These are commonly referred to as ankle strategy and hip strategy, respectively. Healthy individuals primarily move about the ankle joints on a stable surface, and move about the hip joints when the surface comes unstable. COG alignment measures the subject's position on the forceplate at the start of each SOT trial.

The SOT is designed to measure how a subject organizes sensory information. An inability to properly organize sensory information can result in balance instabilities when the environment is shifted. This can include diminished visual clues (darkness, lack of contrast/depth cues), unstable surface (sand, gravel, boat dock), or conflicting

visual stimuli (being in a crowded shopping mall, watching a moving bus.) The SOT attempts to determine if the subject is appropriately able to organize sensory information.

#### 3.4.2. The Adaptation Test (ADT).

The Adaptation Test (ADT) consists of two different conditions (toes-up, toes-down) with five trials of each condition, (Figure 10). The ADT assesses a patient's ability to minimize sway when exposed to surface irregularities and unexpected changes in support surface inclination. Sequences of platform rotations in the toes-up or toes-down direction elicit automatic motor responses. For each platform rotation trial, a sway energy score quantifies the magnitude of the force response required to overcome induced postural instability. Unanticipated toes-up or toes-down rotations elicit automatic responses, which tend to destabilize the patient's balance.

During the first (unexpected) trials, the initial disruptive responses are corrected by secondary responses in the opposing muscles. With each subsequent trial, initial reactions are attenuated and secondary responses strengthened to reduce overall sway. Performance on the ADT requires adequate ankle range of motion and muscle strength, as well as effective motor adaptation. The last of the five trials was utilized per the standard SBM protocol.<sup>71</sup> Here it is assumed that as each trial progresses, the subject learns what to expect and the energy score improves. A good performance score on the ADT requires adequate ankle range of motion and muscle strength, as well as effective motor adaptation.

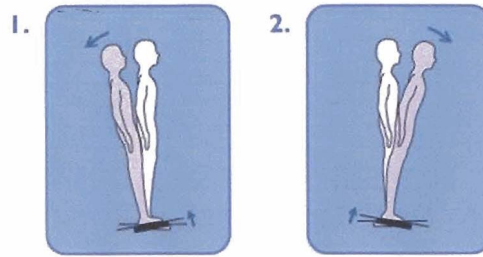

Toes Up and Toes Down Rotations

**Figure 10.** Toes up and toes down rotations. (Courtesy of NeuroCom® International, Inc.)

For each platform rotation trial, a sway energy score, (Equation 11), quantifies the magnitude of the force response required to overcome induced postural instability.

$$SwayEnergy = C1 * PY'(RMS) + C2 * PY''(RMS) \quad \text{Equation 11.}$$

Where the constants C1 and C2 are defined as  $C1 = \frac{1}{in/sec}$  and  $C2 = \frac{0.025}{sec^2}$ .

A printout of this assessment is then produced by the computer, [APPENDIX E]. The average, raw sway and center of force data for all five trials is also provided, however this data was not used during analysis of the study.

The ADT attempts to determine if the subject is appropriately able to suppress inappropriate automatic reactions, as well as ankle joint weakness and restricted range of motion.

### 3.4.3. The Limits of Stability Test (LOS).

The Limits of Stability (LOS) quantifies the maximum distance a person can intentionally displace their center of gravity (COG), i.e. lean their body in a given direction without losing balance, stepping, or reaching for assistance. For each of eight trials, the patient maintains their COG over the base of support as indicated by a cursor display of the COG position relative to a center target, (Figure 11). On command, the patient moves the COG cursor as quickly and accurately as possible towards a second target located on the LOS perimeter (100% of theoretical limits of stability) and then holds the position as close to the target as possible. The patient is allowed up to 8 seconds to complete each trial.

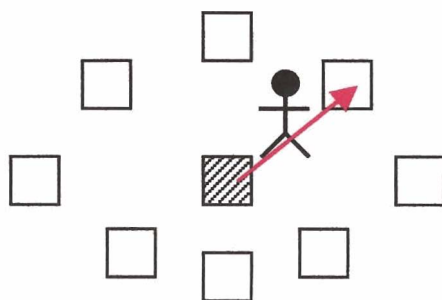

**Figure 11.** LOS screen.

Based on the eight trials of the LOS test, five parameters are calculated: reaction time (RT), movement velocity (MVL), endpoint excursion (EPE), maximum excursion, and directional control (DCL). A printout of this assessment is then produced by the computer, [APPENDIX F].

The RT is measured in seconds and is the time between the command to move given by the system operator and the patient's first move. The MVL is measured in degrees per second and is the average speed of the COG movement. The EPE is expressed as a percentage. It is the distance of the first movement made by the subject towards the designated target. The MXE is expressed as a percentage and is the maximum distance achieved during each trial. The DCL is expressed as a percentage. It compares the amount of movement in the intended direction (towards the designated target) to the amount of extraneous movement (away from the target.) The LOS test attempts to determine if the subject is voluntarily able to move his/her COG to positions within the LOS.

### 3.5. Completion of Subject Testing.

At the completion of testing on the Smart Balance Master<sup>®</sup> system, the patient was released from the safety straps and asked to slowly turn around, rotating 180°. Once the subject was facing the operator, the operator removed the safety vest and assisted the subject with stepping down from the system. The subject then sat down and put socks and shoes back on. The results of the test were printed and reviewed with the subject for his/her information. The subject was then informed that testing was complete and was walked out of the hospital.



## CHAPTER 4: DATA ANALYSIS METHODS

Data was analyzed with SPSS<sup>b</sup>, version 11.0, for Windows and Microsoft Excel, version 9.0.0.3822 for Windows. Means and standard deviations (SDs) for each of the CDP measured were computed for the PD population and compared to those of a healthy population.

### 4.1. Data Variables.

All demographic data (age), scale measurement data (UPDRS, BBS) and Smart Balance Master® data (SOT, ADT, and LOS test scores) were tabulated into an Excel sheet, [APPENDIX G]. The name and last 4 digits of the subject's social security number were also recorded, but were not published.

Based on the parameters each test is designed to measure, SBM tests were divided into two groups for statistical analysis. The first group, (Table 4) lists tests in which the PD subjects were expected to receive lower numerical scores when compared to the healthy population data provided by NeuroCom® International. All of the SOT scores, as well as the LOS endpoint excursion, maximum excursion and directional control measure a percentage or a ratio. The LOS movement velocity measures how quickly the subject is moving in degrees/second.

**Table 4.** Smart Balance Master tests the PD population is expected to score significantly lower in when compared to a healthy population.

CDP Test	Units
SOT Composite	ratio (%)
SOT Somatosensory	ratio (%)
SOT Visual	ratio (%)
SOT Vestibular	ratio (%)
SOT Preferential	ratio (%)
LOS Movement Velocity	degrees/second
LOS Endpoint Excursion	ratio (%)
LOS Maximum Excursion	ratio (%)
LOS Directional Control	ratio (%)

The second group, (Table 5) lists tests in which the PD subjects were expected to receive higher numerical scores when compared to the healthy population data provided by NeuroCom<sup>®</sup> International. The ADT test produces a number score measuring the magnitude of force a subject is required to exert onto the forceplate in order to maintain balance. The smaller the force required to prevent a fall, the ‘better’ the score. LOS reaction time is measured in seconds and is the other test in which the lower the number the subject receives, the ‘better’ the score.

**Table 5.** Smart Balance Master tests the PD population is expected to score significantly higher in when compared to a healthy population.

CDP Test	Units
ADT Toes Up	energy sway
ADT Toes Down	energy sway
LOS Reaction Time	seconds

#### 4.2. Adjusting the NeuroCom Healthy Population Data.

Healthy subjects were not tested by the author for this study. Healthy population scores on the SBM system were provided in the appendix of the NeuroCom<sup>®</sup> International, Inc operator’s manual.<sup>a</sup> However, the raw data from was unavailable. Only healthy population means and standard deviations, divided by age groups 60-69, and 70-79,

[APPENDIX H], were available from the NeuroCom<sup>®</sup> International, Inc for statistical analyses. Calculations were performed to combine these two subpopulations into a single control group with an age range of 60-79 years (Equations 6-9).

The only other demographic information known regarding this data was the breakdown by gender. In the age group 60-69, there were 12 males and 14 females. In the age group 70-79 there were 15 males and 14 females.

$$\bar{Y} = \frac{\sum Y_i}{m} = \frac{(\bar{Y}_a * m_a) + (\bar{Y}_b * m_b)}{m_a + m_b} \quad \text{Equation 6.}$$

Where,  $\bar{Y}_a$  : mean of the NeuroCom healthy population, age range 60-69

$m_a$  : NeuroCom healthy population size, age range 60-69

$\bar{Y}_b$  : mean of the NeuroCom healthy population, age range 70-79

$m_b$  : NeuroCom healthy population size, age range 70-79

$$S_2 = \sqrt{\frac{\sum (Y_i - \bar{Y})^2}{m - 1}} \quad \text{Equation 7}$$

Rearrange Equation 7:

$$\sum (Y_i - \bar{Y})^2 = S_2^2 (m - 1) = s_a^2 (m_a - 1) + s_b^2 (m_b - 1) \quad \text{Equation 8.}$$

Where,  $s_a$  : standard deviation of the NeuroCom healthy population, age range 60-69

$s_b$  : standard deviation of the NeuroCom healthy population, age range 70-79

$$S_2 = \sqrt{\frac{s_a^2 (m_a - 1) + s_b^2 (m_b - 1)}{(m_a + m_b) - 1}} \quad \text{Equation 9.}$$

The newly calculated  $m$ ,  $\bar{Y}$ , and  $S_2$  [APPENDIX I] were then used to compare the performance of patients with PD to that of normal subjects of a similar age. A sample calculation is included in Appendix K.

### 4.3. Data Population Characteristics.

Before any statistical test can be performed on the acquired data sets, there are two characteristics, which were described:

- 1) Are the data sets from each population of a normal distribution?
- 2) Are the comparing data sets of equal variances?

#### 4.3.1. Determining Normal Distribution of Population Data

NeuroCom<sup>®</sup> International, Inc has stated the published collection of data for a healthy population reflects a normal distribution.<sup>71</sup>

Outliers were defined in this study as any value greater or less than 3-standard deviation from the norm. Specifically, this rule applied to subjects deemed unmeasurable by the SBM system, as a result of recurring falls during testing. This assumption was made based on observation that falls during testing were not determined to be a normal occurrence in the PD population. Therefore, any subject's test with recurring falls, resulting in a score of zero on a SOT or LOS test or a score of 200 on the ADT test was removed from the population before data analysis. With removal of these outliers, this lowered the size of the PD study group depending on the specific tests from 45–51 subjects.

Data distribution for both the UPDRS and BBS scores as well as the twelve CDP measurement scores of the PD population was characterized by referring to a combination of skewness and kurtosis values, (Table 6) as well as histogram and P-P plots, [APPENDIX J]. All visual representations were calculated and developed utilizing

SPSS software. Skewness and kurtosis calculations were performed utilizing Microsoft Excel. Calculated skewness and kurtosis statistics, (Equations 10 and 11), showed all data sets to have a normal distribution, ( $\alpha=0.05$ ). Further observation of data set histograms and P-P plots appeared to agree with these findings. A sample calculation is included in Appendix K.

$$\text{Skewness Value} = \text{TestStatistic} \pm 1.96 \times \text{Standard Deviation} \quad \text{Equation 10.}$$

$$\text{Kurtosis Value} = \text{TestStatistic} \pm 1.96 \times \text{Standard Deviation} \quad \text{Equation 11.}$$

**Table 6. Skewness and Kurtosis Tests: Normal Distribution Results.**

CDP Test	Skewness			Normal Distribution?	Kurtosis			Normal Distribution?
	statistic	+ CI	- CI		statistic	+ CI	- CI	
UPDRS	0.926	1.598	0.254	Yes	-0.029	1.3	-2.561	Yes
BBS	-0.503	0.169	-1.175	Yes	-0.701	0.62	-1.916	Yes
SOT Comp	-0.935	-0.282	-1.588	Yes	0.302	1.59	-2.81	Yes
SOT Som	-0.071	0.59	-0.732	Yes	0.34	1.64	-2.87	Yes
SOT Vis	-1.709	-1.048	-2.37	Yes	2.803	4.13	-5.235	Yes
SOT Vest	-0.606	0.047	-1.259	Yes	-0.731	0.56	-1.819	Yes
SOT Pref	0.555	1.221	-0.111	Yes	1.703	3.01	-4.201	Yes
ADT Toe Up	0.728	1.4	0.056	Yes	0.166	1.49	-2.749	Yes
ADT Toe Dn	0.672	1.325	0.019	Yes	-0.337	0.95	-2.197	Yes
LOS RT	-0.085	0.609	-0.779	Yes	-0.531	0.85	-2.16	Yes
LOS MVL	1.185	1.846	0.524	Yes	2.57	3.87	-5.011	Yes
LOS EPE	0.202	0.863	-0.459	Yes	0.22	1.52	-2.755	Yes
LOS MXE	-0.29	0.371	-0.951	Yes	-0.178	1.12	-2.373	Yes
LOS DCL	-0.518	0.176	-1.212	Yes	-0.202	1.16	-2.476	Yes

#### 4.3.2. F-Test: Equal Variance Test.

Equal variance between population data sets was determined by calculating the F-statistic, (Equation 12).

$$F = \frac{S_1^2}{S_2^2} \quad \text{Equation 12.}$$

Where  $S_1$  = sample variance of the PD Population and  $S_2$  = sample variance of the healthy population. A sample calculation is included in Appendix K. The populations were found to have unequal variances for each of the twelve CDP measurements, excluding ADT Toes Down, LOS Endpoint Excursion, LOS Maximum Excursion and LOS Directional Control, (Table 7). The critical F-value was found using a Student's  $t$ -distribution table.<sup>24</sup>

**Table 7.** F-Test: Unequal Variance Results.

CDP Test	PD		NeuroCom		Fobs	F <sub>0.05</sub>	Reject Ho
	S <sub>1</sub>	N <sub>1</sub>	S <sub>2</sub>	N <sub>2</sub>			
SOT Composite	12.377	51	5.651	55	4.797	1.5757	X
SOT Somatosensory	3.946	50	6.091	55	2.383	1.5757	X
SOT Visual	14.13	50	5.845	55	5.844	1.5757	X
SOT Vestibular	24.349	51	9.804	55	6.168	1.5757	X
SOT Preferential	14.563	49	11.273	55	1.669	1.5757	X
ADT Toes Up (5th)	21.085	48	14.505	55	2.113	1.5859	X
ADT Toes Down (5th)	17.957	51	20.049	55	1.247	1.5757	
LOS Reaction Time	0.527	45	0.362	55	2.119	1.6096	X
LOS Movement Velocity	0.998	50	1.374	55	1.895	1.5757	X
LOS Endpoint Excursion	15.069	50	12.139	55	1.541	1.5757	
LOS Maximum Excur.	17.379	50	14.13	55	1.513	1.5757	
LOS Directional Control	10.079	45	8.038	55	1.572	1.6031	

#### 4.4. T-Test: Significantly Different Population Means Test.

Once the data sets were found to have a normal distribution, the twelve CDP test score means of the PD population were compared to the twelve test score means of a population without PD, provided by the NeuroCom<sup>®</sup> International, Inc. As the comparative populations have unequal sample sizes and unequal sample variances (F-test,  $\alpha=0.05$ ), a one-tailed Student's  $t$ -test ( $P<0.05$ ) for independent samples was used (equation 11).

The  $t$ -distribution test is the tool used to measure the degree of significant difference between the mean test scores <sup>76</sup> of the PD population (N=51) and the NeuroCom healthy population (N=55).

Studies have shown the validity of the unpaired  $t$ -test is not severely compromised by assuming equal variance, when they are not actually equal, as long as the population sizes are equal. <sup>48</sup> However, when population sizes are not equal (for this study, the population size varies) and sample variances are not always equal, the accuracy of the test ratio can be affected. Therefore, the  $t$ -test ratio is modified so that it is no longer based on a pooled variance estimate, but is based on the separate variances of the two populations, (Equation 11).

$$T_{\text{obs}} = \frac{\bar{X} - \bar{Y}}{\sqrt{\frac{S_1^2}{n} + \frac{S_2^2}{m}}}$$

*Equation 11*

Where,  $\bar{X}$  : mean of the PD population

$S_1$  : standard deviation of the PD population

$n$  : PD population size

$\bar{Y}$  : mean of the NeuroCom healthy population

$S_2$  : standard deviation of the NeuroCom healthy population

$m$  : NeuroCom healthy population size

The degrees of freedom were also adjusted, modifying the critical  $t$ -value, (Equation 12). The critical  $t$ -value was found using a Student's  $t$ -distribution table. <sup>24</sup>

$$df = \frac{\left(\frac{S_1^2}{n} + \frac{S_2^2}{m}\right)^2}{\left(\frac{S_1^2}{n}\right)^2 \left(\frac{1}{n-1}\right) + \left(\frac{S_2^2}{m}\right)^2 \left(\frac{1}{m-1}\right)}$$

*Equation 12.*

The *t*-test chosen is designed only to compare two separate sample population means. Tests of significant difference were 1-tailed with  $\alpha = 0.05$ . A sample calculation is included in Appendix K.

#### 4.4.1. P-Value Test.

The p-values were calculated to determine the probability that the PD sample population tested could have been drawn from the worldwide PD population. The p-value is a statistical significance test representing the probability of obtaining values of the test statistics that are equal to or greater in magnitude than the observed test statistic. The p-values were obtained from the Student's t-distribution table.<sup>24</sup>

#### 4.5. Correlation Analysis.

A correlation analysis was performed, to determine which CDP measurements held a strong correlation when compared to UPDRS and BBS scores. Pearson's Product Moment Correlation (Pearson's correlation) was performed utilizing SPSS statistical software. Pearson's correlation reflects the degree of linear relationship between two variables ranging from +1 to -1. A correlation of +1 means that there is a perfect positive linear relationship between variables. The analysis was two-tailed, with a population size of 48. Three subjects were not included in the correlation portion of the analysis because their UPDRS and BBS scores were not available.



## CHAPTER 5: RESULTS

### 5.1. Demographic Data

Participants were 49 male patients and 2 female patients at the PADRECC clinic. The average age of patients at study initiation was  $72.18 \pm 6.98$  years [range: 59–82], (Table 7).

### 5.2. Clinical Data

The average score on the UPDRS motor examination for all subjects was  $16.75 \pm 6.77$  [range: 7–33], (Table 8). The average BBS score for all subjects was  $45.85 \pm 6.41$  [range: 31–55], (Table 8).

**Table 8.** Demographic and clinical variables of study subjects (N=51)

<b>Variables</b>	<b>Mean <math>\pm</math> SD</b>	<b>Range</b>
<b>Age (years)</b>	$72.18 \pm 6.98$	59 – 82
<b>UPDRS</b>	$16.75 \pm 6.77$	7 – 33
<b>BBS</b>	$45.85 \pm 6.41$	31 – 55

### 5.3. Comparative Population Means Data

The first group, (Table 4) was analyzed under the hypothesis of the PD population scores measuring significantly lower when compared to a healthy population, (Table 9).

They were tested with the null hypothesis:

$$H_0: \bar{X} \geq \bar{Y}; H_a: \bar{X} < \bar{Y}$$

**Table 9.** Significant difference of Smart Balance Master test scores comparing PD population (N=51) and NeuroCom healthy population (N=55),  $\alpha = 0.05$ : Part 1.

CDP Test	PD Population			Healthy Population			t-test			P-value	Reject Ho
	X	S <sub>1</sub>	N <sub>1</sub>	Y	S <sub>2</sub>	N <sub>2</sub>	T <sub>obs</sub>	dof	T <sub>0.05</sub>	P <sub>0.05</sub>	
<b>SOT Comp</b>	66.49	12.377	51	75.09	5.651	55	-4.54	68.8	-1.667	< 0.0005	X
<b>SOT Som</b>	95.71	3.946	50	96.49	6.091	55	-0.79	93.4	-1.661	0.28	
<b>SOT Vis</b>	81.95	14.132	50	88.76	5.845	55	-3.17	64	-1.669	0.001	X
<b>SOT Vest</b>	44.49	24.349	51	69.24	9.804	55	-6.77	64.8	-1.669	< 0.0005	X
<b>SOT Pref</b>	101.5	14.563	49	96.98	11.27	55	1.753	90.1	1.662	0.04	X
<b>LOS MVL</b>	2.02	0.998	50	3.736	1.374	55	-7.37	98.4	-1.661	< 0.0005	X
<b>LOS EPE</b>	47.54	15.069	50	70.42	12.14	55	-8.51	94.1	-1.661	< 0.0005	X
<b>LOS MXE</b>	60.96	17.379	50	87.18	14.13	55	-8.43	94.6	-1.661	< 0.0005	X
<b>LOS DCL</b>	69.67	10.079	45	72.18	8.038	55	-1.35	83.3	-1.663	0.08	

The second group, (Table 5) was analyzed under the hypothesis of PD population scores measuring significantly higher when compared to a healthy population, (Table 10).

They were tested with the null hypothesis:

$$H_0: \bar{X} \leq \bar{Y}$$

$$H_a: \bar{X} > \bar{Y}$$

**Table 10.** Significant difference of Smart Balance Master test scores comparing PD population (N=51) and NeuroCom healthy population (N=55),  $\alpha = 0.05$ : Part 2.

CDP Test	PD Population			Healthy Population			t-test			P-value	Reject Ho
	X	S <sub>1</sub>	N <sub>1</sub>	Y	S <sub>2</sub>	N <sub>2</sub>	T <sub>obs</sub>	dof	T <sub>0.05</sub>	P <sub>0.05</sub>	
<b>ADT Toes Up (5th)</b>	66.35	21.09	48	62.92	14.51	55	0.949	81.7	1.664	0.16	
<b>ADT Toes DN (5th)</b>	57.61	17.96	51	54.82	20.05	55	0.755	104	1.66	0.23	
<b>LOS RT</b>	1.66	0.527	45	0.979	0.362	55	7.363	75.4	1.665	< 0.0005	X

All CDP measurements of the PD population, with the exception of SOT Somatosensory subscore ( $\rho=0.28$ ), LOS Directional Control subscore ( $\rho=0.08$ ), ADT Toes Up 5<sup>th</sup> ( $\rho=0.16$ ), and ADT Toes Down ( $\rho=0.23$ ), were significantly different in comparison to the healthy population at a level of  $\alpha=0.05$ .

#### 5.4. Correlational Data

Correlation analysis utilizing Pearson's  $\rho$  found that not all of the CDP measurements are indicative of what the UPDRS or BBS are designed to measure, (Table 11). The correlation analysis was used to determine which CDP subscores are most appropriate to use when determining PD postural instabilities.

A strong positive correlation was found between the BBS and SOT Composite, SOT Visual, SOT Vestibular, LOS Movement Velocity, LOS Endpoint Excursion, LOS Maximum Excursion and LOS Directional Control subscores. A positive correlation indicates that as the BBS score decreases (measures more postural instability) the CDP subscores also decrease. A strong negative correlation ( $\alpha=0.01$ ) was found between the BBS and ADT Toes Down (5<sup>th</sup> trial) subscore and Age. A strong negative correlation was also found between the UPDRS and SOT Composite and SOT Vestibular subscores. A moderate negative correlation ( $\alpha=0.05$ ) was found between the UPDRS and LOS Maximum Excursion subscore. A negative correlation indicates that as the BBS score decreases (measures more postural instability) the CDP subscores as well as age increase.

**Table 11.** Pearson's  $\rho$  correlation of CDP measurements to UPDRS and BBS scores.

CDP Tests	UPDRS (r value)	Significance	BBS (r value)	Significance
SOT Comp	-0.428	**	0.501	**
SOT Som	-0.015		0.089	
SOT Vis	-0.224		0.478	**
SOT Vest	-0.474	**	0.443	**
SOT Pref	-0.006		0.059	
ADT Toes Up 5th	0.125		-0.21	
ADT Toes Down 5th	0.118		-0.37	**
LOS RT	0.086		-0.05	
LOS MVL	-0.22		0.399	**
LOS EPE	-0.23		0.552	**
LOS MXE	-0.311	*	0.562	**
LOS DCL	-0.101		0.4	**
Age	0.116		-0.43	**

## CHAPTER 6: DISCUSSION

### 6.1. Describing the Balance Deficits of the PD Patient.

This study demonstrates that there were significant differences measured by CDP, using the Smart Balance Master<sup>®</sup> system, when comparing a PD population to an age-matched healthy population. While these abnormalities of postural instability were expected given the nature of PD, the specific areas of normal balance functioning in this patient population was not anticipated. The specific aspects of postural instability identified by the SOT, LOS and ADT tests and their respective subscales may point to either the selective neurologic deficits associated with PD or the effect of varying severity of PD in this investigation. It is important to note, the nature of this study utilized only relatively high-functioning PWP who could fully participate in the testing procedures. This requirement limited the generalizability of these results to those with early or mild PD.

### 6.1.1. The Sensory Organization Test (SOT).

The Sensory Organization Test provides five measurements or subscales whose values can provide insight to the clinician as to which sensory system(s) may be contributing to instability, as well as a more detailed treatment approach. The mean Composite subscore of the PD population was significantly lower than that of a healthy population. This subscore represents an overall performance level of the patient. A lower score suggests the PD population was unable to maintain balance and a stable position during the SOT test procedure. The lower score may imply the overall balance deficit of the PWP is related to an off balance center of gravity, hip or ankle dominant strategy analysis or abnormal sensory scores. The mean Visual and Vestibular subscores of the PD population were both significantly lower than those of a healthy population. These subscores are designed to indicate how well the patient utilizes their visual and vestibular systems, respectively. The mean Preferential Visual subscore of the PD population was hypothesized to be significantly lower than that of a healthy population. However, analysis revealed the mean subscore to be significantly greater in comparison to a healthy population, suggesting a PWP will use the visual system more than other sensory systems when compared to a healthy population. These findings are counterintuitive, given the increased prevalence of visual scanning difficulties seen with PD. Further investigation into this observation is warranted. The mean Somatosensory subscore of the PD population was not significantly lower than that of a healthy population. This finding suggests that when working to maintain balance, the PD population utilized the somatosensory system to the same degree that a healthy

population does. Therefore the Somatosensory subscore does not appear to be a useful tool for evaluating the postural instabilities specific to a PD patient.

### 6.1.2. The Adaptation Test (ADT).

The Adaptation Test provides measurements used to describe a patient's ability to stabilize balance using a minimum force when successively shifted off balance. The mean ADT Toes Up 5<sup>th</sup> subscore and ADT Toes Down 5<sup>th</sup> subscore of the PD population were not significantly greater than that of a healthy population. This finding suggests that when successively shifted forward or backward and off balance, the PD patient does not supply a significantly greater force to maintain balance in comparison to a patient without PD.

### 6.1.3. The Limits of Stability Test (LOS).

The Limits of Stability test provided five measurements used to describe the subject's mobility and range of motion, and can be used to quantify the current abilities of the patient. Our findings support the theory that the Smart Balance Master<sup>®</sup> system has the capability to accurately quantify balance deficits specific to PD as seen during cue-induced motion. The mean Reaction Time subscore of the PD population was significantly higher than that of a healthy population. This subscore quantified the degree

to which this response time has slowed and supports the observation that a PD patient often take longer to respond to a motion cue. The mean Movement Velocity subscore of the PD population was significantly lower than that of a healthy population. This subscore quantified the velocity of a PWP once motion begins and supports the observation of a slower motion. Following that same concept of a slower velocity, the mean Endpoint Excursion and Maximum Excursion subscores of the PD population were also significantly lower than that of a healthy population. This supported the observation of a PWP will not shifting their weight as far as a patient without PD. Further, a lower MXE subscore suggested the PWP, even if they are able to shift their weight (e.g., place majority of weight on the right foot), may not be able to maintain that new position for an extended period of time. The MXE subscore also allows the clinician to ignore overshoot by a patient who is able to weight shift, but not able to direct their position to a specific target.

## 6.2. Interpreting Abnormal SBM Scores for a PD Patient.

Once it has been determined a PD patient possesses a particular balance deficit, it is vital the operator correctly interpret the meaning of the different test scores, and their functional implications for a patient.

### 6.2.1. The Implications of an Abnormal SOT Score for a PD Patient.

Patients with abnormal SOT scores usually experience difficulty with surface irregularities or misunderstood visual cues (standing on a street corner, watching a bus drive by). These measurements, particularly the composite and vestibular ratios, can prove valuable when attempting to quantify the particular balance deficits of each PD patient.

The SOT composite score, which takes into consideration all six conditions, is determined abnormal when it falls below the 5<sup>th</sup> percentile of the correct age-matched population. As a guideline, for a patient to be considered as possessing normal postural stability, the composite score must be normal.

### 6.2.2. The Implications of an Abnormal ADT Score for a PD Patient.

Patients with abnormal ADT scores will usually experience difficulty with surface irregularities (gravel) or changes in inclination (tripping). PD patients are often unable to suppress inappropriate automatic reactions. PD patients are often characterized by their diminished ankle strategy. One current method of determining the ankle strategy of a patient is part of the UPDRS-III. During this retropulsion test the patient is asked to face away from the clinician. The clinician braces behind the patient, grasps the patient's shoulders and pulls the patient towards the clinician. Retropulsion is described as how many steps the patient requires before regaining balance. A patient without a balance



deficit would not require any steps and would be able to use ankle strategy to regain balance. PD patients sometimes require 2-4 steps before regaining balance, or must be caught by the clinician.

The ADT test provides a very appropriate and safe method of discerning and even quantifying the ankle strategy of a patient.

### 6.2.3. The Implications of an Abnormal LOS Score for a PD Patient.

Patients with abnormal LOS subscores will usually experience difficulty with weight shifting activities such as taking an object off a shelf or climbing in and out of a bathtub. Patients with a fear of falling may show even lower subscores as they may be unwilling to lean as far as they actually are capable of doing. PD patients who have a history of falls may present this in their Endpoint Excursion and Maximum Excursion scores. The EPE and MXE may also prove to be another valuable quantification of ankle strategy. PD patients often move at a slower speed, something quantified by the Movement Velocity score. The Reaction Time of the PD population also proved to be an indicator of a patient's ability to shift weight.

### 6.3. Correlation between the SBM subscores and UPDRS and BBS scores.

A majority of the Smart Balance Master subscores hold a strong positive or negative correlation ( $\alpha=0.01$ ) to the BBS. This may be due to the design of the BBS, which is intended to specifically measure postural instability. UPDRS, however, measures the overall motor control of the PD patient, including facial expression, finger taps and tremor as examples.

I would like to propose a future look into the ratios provided by the SBM for the SOT and LOS tests. In retrospect, it might have been more valuable to correlate the raw data from each of the six conditions between the two populations, as opposed to correlating the calculated ratios computed by the system. This type of analysis would require testing a minimum of 30 subjects with no known neurological disorders, dementia, or balance deficit. I propose 30 subjects because this number defines a large population. However, after 5-10 subjects are test, a power test should be performed to determine exactly how many subjects are required to test.

While the ratios calculated by the SBM provide valuable insight into the varying postural instability of each PD patient, raw measurements might show a stronger correlation to the findings of the UPDRS or BBS.

Further a breakdown of the UPDRS or BBS scales might also show a stronger correlation. Because different parts of the scales measure different aspects of postural instability, it might prove more meaningful to correlate matching numbers. For example,

the measurements of the SOT test might be compared to numbers 6, 7, 8 and 9 scores in the BBS, [APPENDIX B]. The measurements of the ADT test might be compared to the 'Postural Instability' score in the UPDRS, [APPENDIX A].

#### 6.4. Addressing the Design Specifications of NeuroCom's SBM System.

The data collection and analysis performed in this study present the SBM system as a clinical tool, which can be used to measure the postural instability of a patient. A deeper look will now be taken into the overall reliability of the system when used on the Parkinson's disease population.

##### 6.4.1. The Testing Protocol of the Smart Balance Master system.

The PD population contains a number of persons constrained to abnormal foot positioning. Of concern is the requirement by the SBM system to position the feet prior to testing. During data collection for this study, subjects with abnormal foot positioning were increasing uncomfortable and unstable during testing. This suggests the data collected was not solely a function of PD, but also abnormal foot placement something this study was not designed to test. The SBM tests were not a measure of the subject's day to day balance requirements, but were instead a measure of the subject's postural instability as a result of PD and a new foot position. In general, the foot positioning requirements did not seem to have an effect on the slighter positioning issues of subject

with for example a regular “duck foot” stance. It did affect subjects with an exasperated “duck foot” stance, and those who stood with toes pointing inward.

A suggestion to correct this foot placement requirement is to base all SBM measurements and calculations on the present position of the footing prior to testing, instead of requiring subjects to fit a designed mold. This would require a system that can identify the foot placement of the subject, and then calculate the location of the center of mass of the subject based on his/her individualized foot placement.

#### 6.4.2. The Implications of Instrument Filter Use on PD Subject Response Time.

A person affected with Parkinson’s disease (PWP) exhibits a slowed reaction time and motor response. NeuroCom’s use of a second-order Butterworth filter in the SBM biofeedback system implies any processed signal reported back to the subject is no longer a real time signal. The problem with this is this signal is falsely presented as real time to the patient, as well as the clinical operator. What is the effect of a non-real time biofeedback signal being presented as a real time signal on a PWP subject’s response time? A response time, which has already slowed due to the disease?

If this delayed response time can be determined to further affect the response of the PWP subject, the Smart Balance Master is no longer measuring the pure unaffected movements of PWP subject. The only way to remedy this delay time issue is to use instrumentation so precise that no filtering system is necessary. The resulting signal may have aliases, but there is an opportunity to adjust for these without further distressing an already inhibited PWP reaction time.

**Page Missing**

**Page Missing**

## Literature Cited

1. Alonte A, Grosch K, Brenneman S. (1995) Relationship of scores on the Berg Balance scale to results of the limits of stability portion of the Smart Balance Master suite of tests. *Neurol Report*. 19: 22-23.
2. Badke MB, Shea TA, Miedaner JA, Grove CR. (2004) Outcomes after rehabilitation for adults with balance dysfunction. *Arch Phys Med Rehabil*. 85: 227-233.
3. Berg KO, Wood-Dauphinee S, Williams J, Gayton D. (1989) Measuring balance in the elderly: Preliminary development of an instrument. *Physiother Can*. 41: 304-311.
4. Berg KO, Wood-Dauphinee S, Williams JI, Maki B. (1992) Measuring balance in the elderly: Validation of an instrument. *Can J Public Health*. 83(Suppl 2): S7-S11.
5. Berg K, Maki B, Williams JI, Holliday P, Wood-Dauphinee S. (1992) A comparison of clinical and laboratory measures of postural balance in an elderly population. *Arch Phys Med Rehabil* 73: 1073-1083.

6. Berg K, Wood-Dauphinee S, Williams JI. (1995) The Balance Scale: Reliability assessment for elderly residents and patients with an acute stroke. *Scand J Rehab Med* 27:27-36.
7. Black FO, Angel CR, Pesznecker SC, Gianna C. (2000) Outcome analysis of individualized vestibular rehabilitation protocols. *Am J Otol.* 21:543-551.
8. Black FO. (2001) Clinical status of computerized dynamic posturography in neurotology. *Curr Opin Otolaryngol Head Neck Surg.* 9:314-318.
9. Bloem BR. Postural instability in Parkinson's disease. (1992) *Clin Neurol Neurosurg.* 94(SUPPL): S41-S45.
10. Bloem BR, Beckley DJ, van Hilten BJ, Roos RAC. (1998) Clinimetrics of postural instability in Parkinson's disease. *J Neurol.* 245:669-673.
11. Bloem BR. (2001) Postural instability and falls in Parkinson's disease. *Adv Neurol.* 87: 209-223.
12. Bond JM, Morris M. (2000) Goal-oriented secondary motor tasks: their effects on gait in subjects with Parkinson's disease. *Arch Phys Med Rehabil.* 81:110-116.



13. Botner EM, Miller WC, Eng JJ. (2005) Measurement properties of the Activities-specific Balance Confidence scale among individuals with stroke. *Disabil Rehabil.* 27(4): 156-163.
14. Broglio SP, Tomporowski PD, Ferrara MS. (2005) Balance performance with a cognitive task: a dual-task testing paradigm. *Med Sci Sports Exerc.* 37(4): 689-695.
15. Camicioli R, Panzer VP, Kaye J. (1997) Balance in the healthy elderly: Posturography and clinical assessment. *Arch Neurol.* 54(8): 976-981.
16. Cass SP, Borello-France D, Furman JM. (1996) Functional outcome of vestibular rehabilitation in patients with abnormal sensory-organization testing. *Am J Otol.* 17: 581-594.
17. Chong RKY, Horak FB, Frank J, Kaye J. (1999) Sensory organization for balance: specific deficits in Alzheimer's but not in Parkinson's disease. *J Gerontol A Biol Sci Med Sci.* 54(3): M122-M128.
18. Chong RKY, Jones CL, Horak FB. (1999) Postural set for balance control is normal in Alzheimer's but not in Parkinson's disease. *J Gerontol A Biol Sci Med Sci.* 54A(3): M129-M135.

19. Clark S, Rose DJ, Fujimoto K. (1997) Generalizability of the limits of stability test in the evaluation of dynamic balance among older adults. *Arch Phys Med Rehabil.* 78: 1078-1084.
  
20. Clark S, Rose DJ. (2001) Evaluation of dynamic balance among community-dwelling older adult fallers: A generalizability study of the limits of stability test. *Arch Phys Med Rehabil.* 82(4): 468-474.
  
21. Cocchiarella L, Anderson GBJ. (2000) Guides to the evaluation of permanent impairment, 5/E. American Medical Association Press.
  
22. Coogler C. (1996) Using computerized dynamic posturography to accurately identify nonorganic response patterns for postural control. *Neurol Report.* 20: 12-21
  
23. Derosiers J, Rocette A, Corriveau H. (2005) Validation of a new lower-extremity motor coordination test. *Arch Phys Med Rehabil.* 86:993-998.
  
24. Diem K, Seldrup J, Lentner C. (1982) *Geigy Scientific Tables, Volume 2: Introduction to Statistics, Statistical Tables, Mathematical Formulae*, 8/E. Basle, Switzerland: CIBA-GEIGY Corporation.

25. Dodd K, Hill K, Haas R, Luke C, Millard S. (2003) Retest reliability of dynamic balance during standing in older people after surgical treatment of hip fracture. *Physiother Res Int.* 8(2): 93-100.
26. Egan WE, Fisher DP, Gerber LD, Hatler BS, Ernst GP, Hall C, Henderson N. (2001) Postural sway of subjects wearing the U.S. Army chemical protective ensemble after functional activity. *Aviat Space Environ Med.* 72(9): 831-835.
27. El-Kashlan HK, Shepard NT, Asher AM, Smith-Wheelock M, Telian SA. (1998) Evaluation of clinical measures of equilibrium. *Laryngoscope.* 108: 311-319.
28. Fahn S. Unified Parkinson's Disease Rating Scale, In: Fahn S, Marsden CD, Goldstein M, Calne DB. (1987) *Recent Developments in Parkinson's Disease.* Macmillan: New York.
29. Fetter M, Diener HC, Dichgans J. Recovery of postural control after an acute unilateral lesion in humans. *J Vestib Res.* 1990, 1: 373-383.
30. Gianoli G, McWilliams S, Soileau J, Belafsky P. Posturographic performance in patients with the potential for secondary gain. *Otolaryngol Head Neck Surg,* 2000, 122(1): 11-18.

31. Goebel JA, Sataloff RT, Hanson JM, Nashner LM. Posturographic evidence of nonorganic sway patterns in normal subjects, patients, and suspected malingerers. *Otolaryngol Head Neck Surg.* 1997, 117(4): 293-302.
  
32. Goetz CG, Poewe W, Rascol O, Sampaio C, Stebbins GT, Fahn S, Lang AE, Martinez-Martin P, Tilley B, van Hilten B. State of the art review: The Unified Parkinson's Disease Rating Scale (UPDRS): Status and Recommendations. *Mov Disord*, 2003, 18(7): 738-750.
  
33. Goetz CG, Poewe W, Rascol O, Sampaio C, Stebbins GT, Counsell C, Giladi N, Holloway RG, Moore CG, Wenning GK, Yahr MD, Seidl L. (2004) Movement Disorder Society Task Force on rating scales for Parkinson's disease. Movement Disorder Society Task Force report on the Hoehn and Yahr staging scale: status and recommendations. *Mov Disord.* 19(9): 1020-1028.
  
34. Goetz CG, Stebbins GT. Assuring inter-rater reliability for the UPDRS motor section: utility of the UPDRS teaching tape. *Mov Disord* (2004) 19(12): 1453-1456.
  
35. Gorman WF. Defining malingering. *J Forensic Sci.* 1982, 27:401-407.

36. Guskiewicz KM, Riemann BL, Perrin DH, Nashner LM. (1997) Alternative approaches to the assessment of mild head injury in athletes. *Med Sci Sports Exerc.* 29(7): S213-S221.
  
37. Guskiewicz KM. (2001) Postural stability assessment following concussion: one piece of the puzzle. *Clin J Sport Med.* 11: 182-189.
  
38. Guskiewicz KM, Ross SE, Marshall SW. (2001) Postural stability and neuropsychological deficits after concussion in collegiate athletes. *J Athl Train.* 36(3): 263-273.
  
39. Guskiewicz KM. (2003) Assessment of postural stability following sport-related concussion. *Current Science, Inc., Current Sports Medicine Reports.* 2: 24-30.
  
40. Hageman PA, Leibowitz JM, Blanke D. (1995) Age and gender effects on postural control measures. *Arch Phys Med Rehabil.* 76: 961-965.
  
41. Harris JE, Eng JJ, Marigold DS, Tokuno CD, Louis CL. (2005) Relationship of balance and mobility to fall incidence in people with chronic stroke. *Phys Ther.* 85(2): 150-158.

42. Herdman SJ, Clendaniel RA, Mattox DE, Holliday MJ, Niparko JK. (1995) Vestibular adaptation exercises and recovery: acute stage after acoustic neuroma resection. *Otolaryngol Head Neck Surg.* 113: 77-87.
43. van Hilten JJ, van der Zwan AD, Zwinderman AH, Roos RA. (1994) Rating impairment and disability in Parkinson's disease: Evaluation of the Unified Parkinson's Disease Rating Scale. *Mov Disord.* 9: 84-88.
44. Hoehn MM, Yahr MD. (1967) Parkinsonism: Onset, progression and mortality. *Neurology.* 17: 427-442.
45. Horak FB, Jones-Rycewicz C, Black FO, Shumway-Cook A. (1992) Effects of vestibular rehabilitation on dizziness and imbalance. *Otolaryngol Head Neck Surg.* 106: 175-180.
46. Ingersoll CD, Armstrong CW. (1992) The effects of closed-head injury on postural sway. *Med Sci Sports Exerc.* 24(7): 739-742.
47. Johnell O, Melton LJ 3<sup>rd</sup>, Atkinson EJ, O'Fallon WM, Kurland LT. (1992) Fracture risk in patients with parkinsonism: a population-based study in Olmsted County, Minnesota. *Age Aging.* 21(1): 32-38.

48. Keppel G. Design and Analysis: A Researcher's Handbook, 2/E. (1982) New Jersey: Prentice Hall.
49. Koller EC, Glatt S, Vetere-Overfield B, Hassanein R. (1989) Falls and Parkinson's disease. Clin Neuropharmacol. 12(2): 98-105.
50. Kornetti DL, Fritz SL, Chiu Y, Light KE, Velozo CA. (2004) Rating scale analysis of the Berg Balance Scale. Arch Phys Med Rehabil. 85: 1128-1135.
51. Lajoie Y. Effect of computerized feedback postural training on posture and attentional demands in older adults. (2004) Aging Clin Exp Res. 16(5): 363-368.
52. Leroux A. (2005) Exercise training to improve motor performance in chronic stroke: effects of a community-based exercise program. Int J Rehabil Res. 28(1): 17-23.
53. Li F, Harmer P, Fisher KJ, McAuley E, Chaumeton N, Eckstrom E, Wilson NL. (2005) Tai Chi and fall reductions in older patients: A randomized controlled trial. J Gerontol. 60A(2): 187-194.
54. Liao HF, Mao PJ, Hwang AW. (2001) Test-retest reliability of balance tests in children with cerebral palsy. Dev Med Child Neurol. 43(3): 180-186.

55. Lim LIIK, van Wegen EEH, de Goede CJT, Jones D, Rochester L, Hetherington V, Nieuwboer A, Willems AM, Kwakkel G. (2005) Measuring gait and gait-related activities in Parkinson's patients own home environment: a reliability, responsiveness and feasibility study. *Parkinsonism Relat Disord.* 11: 19-24.
56. Liston RAL, Brouwer BJ. (1996) Reliability and validity of measures obtained from stroke patients using the Balance Master. *Arch Phys Med Rehabil.* 77: 425-430.
57. Louis ED, Levy G, Cote LJ, Mejia H, Fahn S, Marder K. (2002) Diagnosing Parkinson's disease using videotaped neurological examinations: validity and factors that contribute to incorrect diagnoses. *Mov Disord.* 17(3): 513-517.
58. Lun V, Pullan N, Labelle N, Adams C, Suchowersky O. (2005) Comparison of the effects of a self-supervised home exercise program with a physiotherapist-supervised exercise program on the motor symptoms of Parkinson's disease. *Mov Disord.* Apr 18, published online.
59. Mackintosh SFH, Hill K, Dodd KJ, Goldie P, Culham E. (2005) Falls and injury prevention should be part of every stroke rehabilitation plan. *Clin Rehabil.* 19(4): 441-451.



60. Marchese R, Bove M, Abbruzzese G. (2003) Effect of cognitive and motor tasks on postural stability in Parkinson's disease: a posturographic study. *Mov Disord.* **18**(6): 652-658.
61. Martinez-Martin P, Fontan C, Frades PB, Petidier R. (2000) Parkinson's disease: Quantification of disability based on the Unified Parkinson's Disease Rating Scale. *Neurologia.* **15**(9): 382-387.
62. McGuine TA, Greene JJ, Best T, Levenson G. (2000) Balance as a predictor of ankle injuries in high school basketball players. *Clin J Sport Med.* **10**: 239-244.
63. McRae C, Diem G, Vo A, O'Brien C, Seeberger L. (2002) Schwab and England: Standardization of administration. *Mov Disord.* **17**(5): 867-876.
64. Metman LV, Myre B, Verwey N, Hassin-Baer S, Arzbaeher J, Sierens D, Bakay R. (2004) Test-retest reliability of UPDRS-III, dyskinesia scales, and timed motor tests in patients with advanced Parkinson's disease: An argument against multiple baseline assessments. *Mov Disord.* **19**(9): 1079-1084.
65. Monsell EM, Furman JM, Herdman SJ, Konrad HR, Shepard NT. (1997) Computerized dynamic platform posturography. *Otolaryngol Head Neck Surg.* **117**:394-398.

66. Morris M, Iansek R, Smithson F, Huxham F. (2000) Postural instability in Parkinson's disease: a comparison with and without a concurrent task. *Gait Posture*. 12:205-216.
67. Nashner LM, Black FO, Wall C. (1982) Adaptation to altered support and visual conditions during stance: Patients with vestibular deficits. *J Neurosci*. 2(5): 536-544.
68. Nashner LM. (1993) Computerized dynamic posturography. In: Jacobson GP, Newman CV, Kartush JM, editors. *Handbook of balance function testing*. St. Louis: Mosby-Year Book. 280-307.
69. The National Institute of Neurological Disorders and Stroke. Parkinson's Disease. [http://www.ninds.nih.gov/disorders/parkinsons\\_disease/parkinsons\\_disease.htm](http://www.ninds.nih.gov/disorders/parkinsons_disease/parkinsons_disease.htm). Accessed June 2005
70. The National Parkinson Foundation. Parkinson's disease patient education – What the patient should know. <http://www.parkinson.org/pdedu.htm>. Accessed June 2005.
71. NeuroCom International, Inc. (2004) SMART Balance Master system operator's manual, (Version 8.2). Clackamas: Neurocom International, Inc.

72. Nilsson MH, Tornqvist AL, Rehncrona S. (2005) Deep-brain stimulation in the subthalamic nuclei improves balance performance in patients with Parkinson's disease, when tested without anti-parkinsonian medication. *Acta Neurol Scand.* **111**: 301-308.
73. Nova IC, Perracini MR, Ferraz HB. (2004) Levodopa effect upon functional balance of Parkinson's disease patients. *Parkinsonism Relat Disord.* **10**: 411-415.
74. Ondo W, Warrior D, Overby A, Calmes J, Henderson N, Olson S, Jankovic J. (2000) Computerized posturography analysis of progressive supranuclear palsy: A case-control comparison with Parkinson's disease and healthy controls. *Arch Neurol.* **57**:1464-1469.
75. O'Shea S, Morris M, Iansek R. (2002) Dual task interference during gait in people with Parkinson's disease: effects of motor versus cognitive secondary tasks. *Phys Ther.* **82**: 888-897.
76. Portney LG, Watkins MP. (2000) *Foundations of Clinical Research: Applications to Practice*, 2/E. New Jersey: Prentice Hall.

77. Qutubuddin AA, Pegg PO, Cifu DX, Brown R, McNamee S, Carne W. (2005) Validating the Berg Balance Scale for patients with Parkinson's disease: A key to rehabilitation evaluation. *Arch Phys Med Rehabil.* 86: 789-792.
78. Ramaker C, Marinus J, Stiggelbout AM, van Hilten BJ. (2002) Systematic evaluation of rating scales for impairment and disability in Parkinson's disease. *Mov Disord.* 17(5): 867-876.
79. Richards M, Marder K, Cote L, Mayeux R. (1994) Inter-rater reliability of the Unified Parkinson's Disease Rating Scale motor examination. *Mov Disord.* 9: 89-91.
80. Rochester L, Hetherington V, Jones D, Nieuboer A, Willems AM, Kwakkel G, van Wegen E. (2004) Attending to the task: Interference effects of functional tasks on walking in Parkinson's disease and the roles of cognition, depression, fatigue, and balance. *Arch Phys Med Rehabil.* 85: 1578-1585.
81. Rose D, Clark S. (2000) Can the control of bodily orientation be significantly improved in a group of older adults with a history of falls? *J Am Geriatr Soc.* 48: 275-282.
82. Sackley C, Richardson P, McDonnell K, Ratib S, Dewey M, Hill HJ. (2005) The reliability of balance, mobility and self-care measures in a population of adults with a learning disability known to a physiotherapy service. *Clin Rehabil.* 19(2): 216-223.

83. Salbach NM, Mayo NE, Robichaud-Eckstrand S, Hanley JA, Richards CL, Wood-Dauphinee S. (2005) The effect of a task-oriented walking intervention on improving balance self-efficacy poststroke: a randomized, controlled trial. *J Am Geriatr Soc.* 53: 576-582.
84. Sargent EW, Goebel JA, Hanson JM, Beck DL. (1997) Idiopathic bilateral vestibular loss. *Otolaryngol Head Neck Surg.* 116(2): 157-162.
85. Siderowf A, McDermott M, Kieburtz K, Blindauer K, Plumb S, Shoulson I, Parkinson's Study Group. (2002) Test-retest reliability of the Unified Parkinson's Disease Rating Scale in patients with early Parkinson's disease: results from a multicenter clinical trial. *Mov Disord.* 17(4): 758-763.
86. Smithsonian, F. (1998) Performance of clinical tests of balance in Parkinson's disease. *J Phys Ther.* 78: 577-592.
87. Stebbins GT, Goetz CG. (2000) Factor structure of the Unified Parkinson's Disease Rating Scale: Motor examination section. *Move Disord.* 15(2): 335-336.

88. Tinetti ME, Speechley M, Ginter SF. (1988) Risk factors for falls among elderly persons living in the community. *N Engl J Med.* 319: 1701-1707.
89. Tyson SF, DeSouza LH. (2004) Reliability and validity of functional balance tests post stroke. *Clin Rehabil.* 18: 916-923.
90. Visser M, Marinus J, Bloem BR, Kijes H, van den Berg BM, van Hilten JJ. (2003) Clinical tests for the evaluation of postural instability in patients with Parkinson's disease. *Arch Phys Med Rehabil.* 84:1669-1674.
91. Voorhees, RL. (1990) Dynamic posturography findings in central nervous system disorders. *Otolaryngol Head Neck Surg.* 103: 96-101.
92. Wade LD, Canning CG, Fowler V, Felmingham KL, Baguley IJ. (1997) Changes in postural sway and performance of functional tasks during rehabilitation after traumatic brain injury. *Arch Phys Med Rehabil.* 78:1107-1111.
93. Wallmann HW. (2001) Comparison of elderly nonfallers and fallers on performance measures of functional reach, sensory organization, and limits of stability. *J Gerontol.* 56A(9): M580-M583.

94. Whitney S, Wrisley D, Furman J. (2003) Concurrent validity of the Berg Balance Scale and the Dynamic Gait Index in people with vestibular dysfunction. *Physiother Res Int.* 8(4): 178-186.
95. Wigglesworth J, Dayhoff N, Suhr J. (1996) The reliability of four measures of postural control using the Smart Balance Master. *J Am Coll Sports Med.* 29: M93-M98.
96. Wolfson LI, Whipple R, Amerman P, Kleinberg A. (1986) Stressing the postural response: a quantitative method for testing balance. *J Am Geriatr Soc.* 34: 845-850.
97. Wood BH, Bilclough JA, Bowron A, Walker RW. (2002) Incidence and prediction of falls in Parkinson's disease: a prospective multidisciplinary study. *J Neurol Neurosurg Psychiatry.* 72: 721-725.
98. Wood-Dauphinee S, Berg K, Bravo G, Williams JL. (1997) The Balance Scale: Responding to clinically meaningful changes. *Canadian Journal of Rehabilitation* 10: 35-50.
99. Yardley L, Burgneay J, Nazareth I, Luxon L. (1998) Neuro-otological and psychiatric abnormalities in a community sample of people with dizziness: a blind, controlled investigation. *J Neurol Neurosurg Psychiatry.* 65(5): 679-684.

## Suppliers

- a. NeuroCom International Inc, 9570 SE Lawnfield Rd, Clackamas, OR 97015.
- b. SPSS Inc, 233 S Wacker Dr, 11<sup>th</sup> Fl, Chicago, IL 60606.



## APPENDIX A

The UNIFIED PARKINSON'S DISEASE RATING SCALE: PART 3  
MOTOR EXAMINATION (UPDRS-III)

<b>Speech</b>	0=Normal 1=Slight loss of expression, diction and/or volume 2=Monotone, slurred but understandable; moderately impaired 3=Marked impairment 4=Unintelligible
<b>Facial Expression</b>	0=Normal 1=Minimal hypomimia, could be normal "poker face" 2=Slight but definitely abnormal diminution of facial expression 3=moderate hypomimia; lips parted some of the time 4=Masked or fixed facies with severe or complete loss of facial expression; lips parted ¼ inch or more
<b>Tremor at Rest</b>	0=Absent
___ RUE	1=Slight and infrequently present
___ LUE	2=Mild in amplitude and persistent or moderate in amplitude, only present intermittently
___ RLE	3=Moderate in amplitude and present most of the time
___ LLE	4=Marked in amplitude and present most of the time
___ Head	
<b>Action or Postural Tremor of Hands</b>	0=Absent
___ R	1=Slight; present with action
___ L	2=Moderate in amplitude; present with action
	3=Moderate in amplitude, with posture holding as well as action
	4=Marked in amplitude, interferes with feeding
<b>Rigidity</b>	0=Absent
___ RUE	1=Slight or detectable only when activated by mirror or other movements
___ LUE	2=Mild or moderate
___ RLE	3=Marked, but full range of motion easily achieved
___ LLE	4=Severe, range of motion achieved with difficulty
___ Head	

**Finger Taps**

\_\_\_\_ R  
\_\_\_\_ L

- 0=Normal  
 1=Mild slowing and/or reduction in amplitude  
 2=Moderately impaired. Definite and early fatiguing. May have occasional arrests in movement.  
 3=Severely impaired. Frequent hesitation in initiating movements or arrests in ongoing movements  
 4=Can barely perform the task

**Hand Movements**

\_\_\_\_ R  
\_\_\_\_ L

- 0=Normal  
 1=Mild slowing and/or reduction in amplitude  
 2=Moderately impaired. Definite and early fatiguing. May have occasional arrests in movement.  
 3=Severely impaired. Frequent hesitation in initiating movements  
 4=Can barely perform the task

**Rapid Alternating Movement of Hands**

\_\_\_\_ R  
\_\_\_\_ L

- 1=Mild slowing and/or reduction in amplitude  
 2=Moderately impaired. Definite and early fatiguing. May have occasional arrests in movement.  
 3=Severely impaired. Frequent hesitation in initiating movements or arrests in ongoing movements  
 4=Can barely perform the task

**Leg Agility**

\_\_\_\_ R  
\_\_\_\_ L

- 1=Mild slowing and/or reduction in amplitude  
 2=Moderately impaired. Definite and early fatiguing. May have occasional arrests in movement.  
 3=Severely impaired. Frequent hesitation in initiating movements or arrests in ongoing movements  
 4=Can barely perform the task

**Arising From A Chair**

- 0=Normal  
 1=Slow; or may need more than one attempt  
 2=Pushes self up from arms of chair  
 3=Tends to fall back and may have to try more than once, but can get up without help  
 4=Unable to arise without help

**Posture**

- 0=Normal erect  
 1=Not quite erect, slightly stooped posture, could be normal for older person  
 2=Moderately stooped posture, definitely abnormal, can be slightly leaning to one side  
 3=Severely stooped posture with kyphosis; can be moderately leaning to one side

**Gait**

- 0=Normal  
 1=Walks slowly, may shuffle with short steps, no festination  
 2=Walks with difficulty, requires little to no assistance, may have some festination, short steps or propulsion  
 3=Severe gait disturbance requiring assistance  
 4=Can not walk at all even with assistance

**Postural Instability**

0=Normal

1=Retropulsion, but recovers unaided

2=Absence of postural response; would fall if not caught by examiner

3=Very unstable, tends to lose balance spontaneously

4=Unable to stand without assistance

**Body Bradykinesia**

0=None

1=Minimal slowness, movements deliberate character, could be normal for older person

2=Mild degree of slowness and poverty of movement which is definitely abnormal. Some reduced amplitude

3=Moderate slowness, poverty or small amplitude of movement

4=Marked slowness, poverty or small amplitude of movement

**Part 3 Score: \_\_\_\_\_**

## APPENDIX B

### The Berg Balance Scale (BBS)

#### 1. SITTING TO STANDING

**INSTRUCTIONS: Please stand up. Try not to use your hands for support.**

- 4 able to stand without using hands and stabilize independently
- 3 able to stand independently using hands
- 2 able to stand using hands after several tries
- 1 needs minimal aid to stand or to stabilize
- 0 needs moderate or maximal assist to stand

#### 2. STANDING UNSUPPORTED

**INSTRUCTIONS: Please stand for 2 minutes without holding.**

- 4 able to stand safely for 2 minutes
- 3 able to stand 2 minutes without supervision
- 2 able to stand 30 seconds unsupported
- 1 needs several tries to stand 30 seconds unsupported
- 0 unable to stand 30 seconds unassisted

**If Subject is able to stand 2 minutes unsupported, score full points for sitting unsupported. Proceed to item #4.**

#### 3. SITTING WITH BACK UNSUPPORTED BUT FEET SUPPORTED ON FLOOR OR ON A STOOL

**INSTRUCTIONS: Please sit with arms folded for 2 minutes.**

- 4 able to sit safely and securely for 2 minutes
- 3 able to sit 2 minutes under supervision
- 2 able to sit 30 seconds
- 1 able to sit 10 seconds
- 0 unable to sit without support 10 seconds

#### 4. STANDING TO SITTING

**INSTRUCTIONS: Please sit down.**

- 4 sits safely with minimal use of hands
- 3 controls descent by using hands
- 2 uses back of legs against chair to control descent
- 1 sits independently but has uncontrolled descent
- 0 needs assistance to sit

#### 5. TRANSFERS

**INSTRUCTIONS: Arrange chair(s) for a pivot transfer. Ask subject to transfer one way toward a seat with armrests and one way toward a seat without armrests. You may use 2 chairs (one with and one without armrests) or a bed and a chair.**

- 4 able to transfer safely with minor use of hands
- 3 able to transfer safely definite use of hands
- 2 able to transfer with verbal cuing and/or supervision
- 1 needs one person to assist
- 0 needs two people to assist or supervise to be safe

#### 6. STANDING UNSUPPORTED WITH EYES CLOSED

**INSTRUCTIONS: Please close your eyes and stand still for 10 seconds.**

- 4 able to stand 10 seconds safely
- 3 able to stand 10 seconds with supervision
- 2 able to stand 3 seconds
- 1 unable to keep eyes closed 3 seconds but stays steady
- 0 needs help to keep from falling

#### 7. STANDING UNSUPPORTED WITH FEET TOGETHER

**INSTRUCTIONS: Place your feet together and stand without holding.**

- 4 able to place feet together independently and stand 1 minute safely
- 3 able to place feet together independently and stand for 1 minute with supervision
- 2 able to place feet together independently but unable to hold for 30 seconds
- 1 needs help to attain position but able to stand 15 seconds feet together
- 0 needs help to attain position and unable to hold for 15 seconds

## 8. FACING FORWARD WITH OUTSTRETCHED ARM WHILE STANDING

**INSTRUCTIONS:** Lift arm to 90 degrees. Stretch out your fingers and reach forward as far as you can. (Examiner places a ruler at end of fingertips when arm is at 90 degrees. Fingers should not touch ruler while reaching forward. The recorded measure is the distance forward that the fingers reach while the subject is in the most forward lean position. When possible, ask subject to use both arms when reaching to avoid rotation of the trunk.)

- 4 can reach forward confidently > 25 cm (10 inches)
- 3 can reach forward > 12 cm safely (5 inches)
- 2 can reach forward > 5 cm safely (2 inches)
- 1 reaches forward but needs supervision
- 0 loses balance while trying/requires external support

## 9. PICK UP OBJECT FROM THE FLOOR FROM A STANDING POSITION

**INSTRUCTIONS:** Pick up the shoe/slipper, which is placed in front of your feet.

- 4 able to pick up slipper safely and easily
- 3 able to pick up slipper but needs supervision
- 2 unable to pick up but reaches 2-5 cm (1-2 inches) from slipper and keeps balance independently
- 1 unable to pick up and needs supervision while trying
- 0 unable to try/needs assist to keep from losing balance or falling

## 10. TURNING TO LOOK BEHIND OVER LEFT &amp; RIGHT SHOULDERS WHILE STANDING

**INSTRUCTIONS:** Turn to look directly behind you, over your left shoulder. Repeat to the right.

- 4 looks behind from both sides and weight shifts well
- 3 looks behind one side only, other side shows less weight shift
- 2 looks sideways only but maintains balance
- 1 needs supervision when turning
- 0 needs assist to keep from losing balance or falling

## 11. TURN 360 DEGREES

**INSTRUCTIONS:** Turn completely around in a full circle. Pause. Then turn a full circle in the other direction.

- 4 able to turn 360 degrees safely in 4 seconds or less
- 3 able to turn 360 degrees safely one side only in 4 seconds or less
- 2 able to turn 360 degrees safely, but slowly
- 1 needs close supervision or verbal cuing
- 0 needs assistance while turning

12. PLACING ALTERNATE FOOT ON STEP OR STOOL WHILE STANDING  
UNSUPPORTED

**INSTRUCTIONS:** Place each foot alternately on the step/stool. Continue until each foot has touched the step/stool 4 times.

- ( ) 4 able to stand independently and safely and complete 8 steps in 20 seconds
- ( ) 3 able to stand independently and complete 8 steps > 20 seconds
- ( ) 2 able to complete 4 steps without aid with supervision
- ( ) 1 able to complete > 2 steps needs minimal assist
- ( ) 0 needs assistance to keep from falling/unable to try

13. STANDING UNSUPPORTED ONE FOOT INFRONT

**INSTRUCTIONS: (DEMONSTRATE TO SUBJECT)** Place one foot directly in front of the other. If you feel that you cannot place your foot directly in front, try to step far enough ahead that the heel of your forward foot is ahead of the toes of the other foot. (To score 3 points, the length of the step should exceed the length of the other foot and the width of the stance should approximate the subject's normal stride width.)

- ( ) 4 able to place foot tandem independently and hold 30 seconds
- ( ) 3 able to place foot ahead of other independently and hold 30 seconds
- ( ) 2 able to take small step independently and hold 30 seconds
- ( ) 1 needs help to step but can hold 15 seconds
- ( ) 0 loses balance while stepping or standing

14. STANDING ON ONE LEG

**INSTRUCTIONS:** Stand on one leg as long as you can without holding.

- ( ) 4 able to lift leg independently and hold > 10 seconds
- ( ) 3 able to lift leg independently and hold 5-10 seconds
- ( ) 2 able to lift leg independently and hold = or > 3 seconds
- ( ) 1 tries to lift leg, unable to hold 3 seconds but remains standing independently
- ( ) 0 unable to try or needs assist to prevent fall

APPENDIX C

IRB CONSENT FORM



VA RESEARCH CONSENT FORM

Subject Name: \_\_\_\_\_ Date: \_\_\_\_\_

Title of Study: The Use of Computerized Posturography Testing to Assess Balance in Individuals with Parkinson's Disease

Principal Investigator: Abu Qutubuddin, MD VAMC-Richmond

This Consent Form Includes Required Elements Of Informed Consent.

Table of Contents:

Title of Research:  
 Sponsor:  
 Protocol No:  
 Investigator name and address:

1. What is this research study about? (Introduction)
2. What is expected of me? (Procedures)
3. Will the research benefit me? (Benefits)
4. What are my alternatives to being a research subject? (Alternative Therapy)
5. What are my risks? (Risks, Inconveniences, Discomforts)
6. Will I get paid? (Compensation)
7. Will I have to pay anything? (Cost of Participation)
8. Does pregnancy prevent me from participating? (Pregnancy)
9. What if I get injured? (Research Related Injury)
10. Are my records safe from the public? (Confidentiality of Records)
11. Do I have to participate in this study or can I withdraw from the study? (Voluntary Participation and Withdrawal)
12. Who should I contact for emergency questions? (Contacts)
13. Date of Consent Form Revision (Consent Version Date)

VA FORM 10-1086 IF MORE THAN ONE PAGE IS USED EACH PAGE MUST BE INDIVIDUALLY WITNESSED  
 Template 10/1/99

IRRB Approved Consent Form  
 Approval Date \_\_\_\_\_  
 Place to be signed below \_\_\_\_\_  
 Patient initials \_\_\_\_\_

**TITLE: The Use of Computerized Posturography Testing to Assess Balance in Individuals with Parkinson's Disease**

**SPONSOR:** N/A

**PROTOCOL NUMBER:**

**SITE INVESTIGATOR:** Abu Qutubuddin, M.D.  
McGuire VA Medical Center  
1201 Broad Rock Blvd.  
Richmond, VA 23249  
Phone No. - (804) 675-5931  
Fax No. - (804) 675-5939

**1. What is this research study about? (Introduction)**

You are being asked to participate in a research study because you have Parkinson's Disease. As part of this study, we will check your balance using computerized posturography, called the Smart Balance Master system.

The purpose of this research is to check the usefulness of the Smart Balance Master System by comparing the results of this system with other measures taken in the evaluation of patients with Parkinson's Disease. The study doctors will also evaluate how well the system predicts whether a patient will fall in the future. Approximately 50 patients will be enrolled into this study.

We will only need your participation for this one hour visit.

**2. What is expected of me? (Procedures)**

The study doctor will review your medical records and discuss your Parkinson's Disease symptoms with you. If you are selected for this study, you will be tested on the Smart Balance Master System. You will be secured in a safety harness and will be asked to step into an open booth. The booth has a moveable floor-plate and a computer screen on the inside wall. The researcher will provide instructions and ask you to move pictures on the computer screen by shifting your body weight. During different parts of this study you will be asked to close your eyes and/or to stand on one foot. At all times you will be secured by the safety harness to prevent you from falling and there will be a person nearby should you need help. This test will take approximately 60 minutes. You will also undergo the standard of care physical examination that every Parkinson's Disease patient receives.

If at any time during the testing you feel uncomfortable and wish to stop you can tell the study person in the room with you and they will stop the testing.

IRB Approved Consent Form

Approval Date: 1/25/05

Not to be signed after 1/25/05

**3. Will this research benefit me? (Benefits)**

There are no direct benefits to you from participating in this study. Future patients may benefit from the knowledge gained from this study.

**4. What are my alternatives to being a research subject? (Alternative Therapy)**

This is not a treatment study. Your alternative is not to participate.

**5. What are my risks? (Risks, Inconveniences, Discomforts)**

The balance testing is performed under controlled conditions and you will have a safety harness (a padded vest that is attached to stable overhead supports) on during the entire testing procedure. With any testing of balance, there is a risk of falling. The safety harness is designed to greatly reduce that risk and to prevent injury.

Your Parkinson's disease may improve, may get worse or may not change while you are participating in this study.

**6. Will I be paid? (Compensation)**

You will not be paid to participate in this study.

**7. Will I have to pay anything? (Cost of Participation)**

The office visit, medical history, physical examination, and balance testing in this study will be provided to you at no cost.

**8. Does pregnancy prevent me from participating? (Pregnancy)**

Every effort will be made to have females enter this study. Pregnancy does not prevent you from participating in this study.

**9. What if I get injured? (Research Related Injury)**

In the event of an injury resulting from your participation in this research study, McGuire Veterans Affairs Medical Center may or may not provide compensation, depending on applicable federal regulations. If injury occurs at the VAMC, medical treatment will be available at the VAMC.

No other compensation such as lost wages or payments for emotional distress will be paid.

MIRB Approval/Consent Form  
Approval Date: 11/15/04  
Not to be signed after 11/15/04

**10. Are my records safe from the public? (Confidentiality of Records)**

Federal law requires that we get your permission to use and share your health information. This permission is called an Authorization. The information we will use may include your medical history, the results of physical exams, blood tests, x-rays and other tests and procedures. It also includes information from your medical records, and the information we collect while you are in this study.

Your health information will be used to see if you qualify for this study. It will also be used to follow your health during the study, and to measure the effects of study devices. Your health information will be used to determine the results of the study, and possibly to develop new tests, procedures, and commercial products (products for sale). It may be checked to see if studies are being done correctly.

Authorized VA employees, the McGuire Institutional Review Board, federal agencies, such as the Food and Drug Administration, and the Office for Human Research Protections may review your records. All of these persons or groups are required by law to protect your health information. The results of this research study may also be presented at meetings or in publications, but your name will not be used.

During the study, you will not be allowed to look at the information that is collected about you. If you ask, this information will be made available to you after the study ends and the results are known. However, some of the information collected about you during this study will be put in your regular patient medical records. That information will be available to you, your doctor and others providing you care.

This Authorization has no expiration date. By signing this consent form, you are giving permission for the use and sharing of your health information for purposes of the study at any time in the future. You may revoke or cancel this Authorization at any time by contacting Dr. Abu Qutubuddin in writing. If you revoke your Authorization, you will be removed from the study. However, standard medical care and any other benefits to which you are entitled will not be changed. Revoking your Authorization only affects the use and sharing of information after your written request has been received. Information that has already been collected may still be used.

As part of your right to voluntarily participate in this study, you have the right to refuse to sign this consent form and not be a part of the study. You can also tell us you want to withdraw from the study at any time without canceling the Authorization to use your data. By signing this form, you authorize the use and/or sharing of your health information.

MIRB Approved Consent Form  
Approval Date: 1/15/05  
IRB #: 05-001

**11. Do I have to participate in this study or can I withdraw from the study?  
(Voluntary participation and withdrawal)**

Participation in this study is voluntary and you may refuse to participate without penalty or loss of benefits to which you are otherwise entitled. The investigators will answer any questions you may have about the study. You are free to withdraw your consent and discontinue participation at any time. If you decide to withdraw from this study, you should contact Dr. Qutubuddin. Discontinuation will in no way affect or jeopardize the quality of care you receive at this institution now or in the future or your right to participate in other studies for which you are eligible.

Your study doctor may also withdraw you if you do not follow the study doctor's directions or if your medical conditions change. The study doctor, McGuire IRB or government regulatory agencies, could discontinue the entire study at any time if the safety of research subjects is found to be at significant risk. If this study is stopped for any reason, you will be asked to go through a final examination to check your general health.

Any significant new findings that develop during the course of the research study that in the opinion of the study doctor may affect your willingness to continue to participate will be provided to you as soon as possible.

**12. Who should I contact for emergency questions? (Contacts)**

If you have any questions regarding this study, unexpected reactions, or you are injured and become ill as a result of participation in this study, please call (24 hours):

Telephone Numbers:	7:30 a.m. - 4:00 p.m.	After Hours
Abu Qutubuddin, MD.	(w) (804) 675-5931	(804) 351-7820
David Cifu, MD.	(w) (804) 675-5931	(804) 997-6468

If you are unable to reach any of the health care providers listed and need immediate medical assistance for a research related injury please call the VAMC hospital operator at 800-784-8381 and ask for the Emergency Room physician to obtain advice. You may also call the Emergency Room directly at 804-675-5527. If you have any questions concerning your rights as a research participant, you may contact the McGuire Institutional Review Board (IRB) at 804-675-5676. The IRB is responsible for reviewing research in human subjects and verifying that safety, integrity and human rights of the subjects are protected.

**13. Date of Consent Form Revision: January 25, 2005**

McGIRB Approved Consent Form

Approval Date: 2/16/05

Not to be signed after: 2/16/05

Department of Veterans Affairs

Subject Name: \_\_\_\_\_ Date: \_\_\_\_\_

**Title of Study: The use of Computerized Posturography Testing to Assess Balance in Individuals with Parkinson's Disease**

Principal Investigator: Abu Oubaidin, MD VAMC: Richmond

RESEARCH SUBJECTS' RIGHTS: I have read or have had read to me all of the above.

Dr. Oubaidin or one of his associates has explained the study to me and answered all of my questions. I have been told of the risks or discomforts and possible benefits of the study. I have been told of other choices of treatment available to me.

I understand that I do not have to take part in this study, and my refusal to participate will involve no penalty or loss of rights to which I am entitled. I may withdraw from this study at any time without penalty or loss of VA or other benefits to which I am entitled. The results of this study may be published, but my records will not be revealed unless required by law.

I understand my rights as a research subject, and I voluntarily consent to participate in this study. I understand what the study is about and how and why it is being done. I will receive a signed and dated copy of this consent form.

_____ Subject's Signature	_____ Date/Time
_____ Signature of Subject's Representative *	_____ Print Name/Date
_____ Signature of Witness	_____ Print Name/Date
_____ Signature of Person Obtaining Informed Consent	_____ Print Name/Date
_____ Signature of Investigator	_____ Print Name/Date

\*Only required if subject is not competent.

VA FORM 10-1086 IF MORE THAN ONE PAGE IS USED EACH PAGE MUST BE CONSECUTIVELY NUMBERED

## APPENDIX D

### THE SENSORY ORGANIZATION TEST (SOT) PRINTOUT EXAMPLE

Name: ██████████ **Diagnosis:** Parkinson's Disease **File:** FD119.DRX  
**ID:** ██████████ **Operator:** McGuirk, Theresa E **Date:** 11/30/2004  
**Date of Birth:** 8/6/1935 **Referral Source:** patient's referral **Time:** 14:21:45  
**Height:** 5' **Comments:**

**Sensory Organization Test**  
 (Swayy Referenced Gain: 1.0)

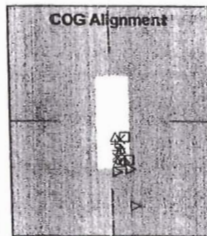
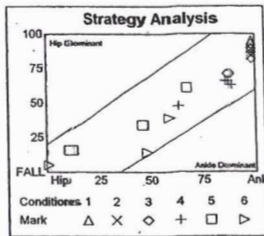
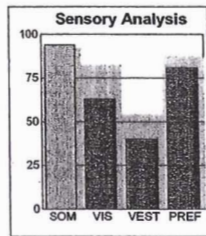
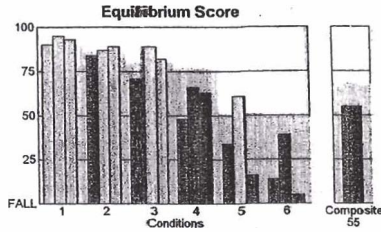

**Data Range Note:** NeuroCom Data Range: 60-69

Post Test Comment:  
 a few falls



APPENDIX E

THE ADAPTATION TEST PRINTOUT EXAMPLE

Name: ██████████      **Diagnosis:** Parkinson's Disease      **File:** FD11J.DRX  
 ID: ██████████      **Operator:** McGuirk, Theresa E      **Date:** 11/30/2004  
**Date of Birth:** 8/6/1935      **Referral Source:** patient's referral      **Time:** 14:35:07  
**Height:** 5'8"      **Comments:**

### Adaptation Test

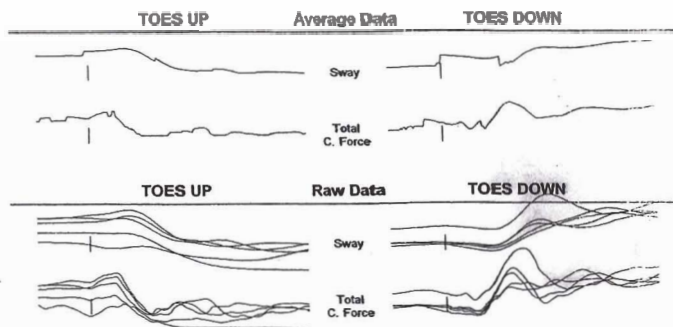
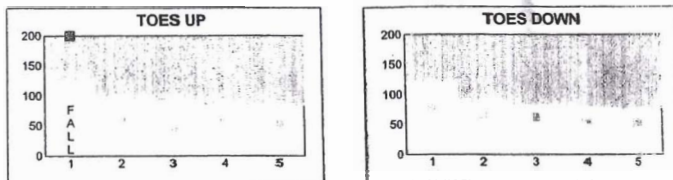

□ = 5 degrees; 20 lb force; 4 in force center displacement  
 2.5 seconds      Sampling rate 100 Hz

**Data Range Note:** NeuroCom Data Range: 60-69

Post Test Comment:

## APPENDIX F

### THE LIMITS OF STABILITY TEST (LOS) PRINTOUT EXAMPLE

Name: ██████████ **Diagnosis:** Parkinson's Disease **File:** FD110.D1??  
 ID: ██████████ **Operator:** McGuirk, Theresa E **Date:** 11/30/2004  
 Date of Birth: 8/6/1935 **Referral Source:** patient's referral **Time:** 14:39:21  
 58" **Comments:**

**Limits Of Stability**

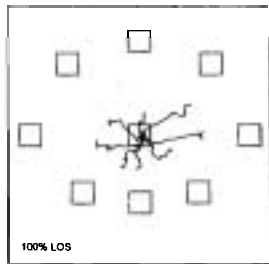

Transition	RT (sec)	MVL (deg/sec)	EPE (%)	MXE (%)	DCL (%)
1 (F)	2.78	0.5	22	22	72
2 (BF)	1.07	0.7	40	56	71
3 (R)	1.07	1.0	37	59	90
4 (RB)	2.22	0.8	38	42	72
5 (B)	1.60	0.8	25	50	77
6 (LB)	2.37	0.8	35	43	80
7 (L)	2.35	1.2	31	40	76
8 (LF)	2.04	0.8	30	31	66

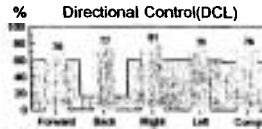
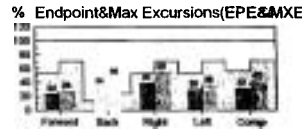
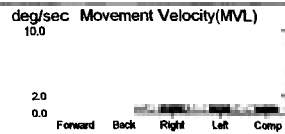
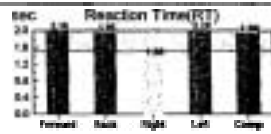

**Data Range Note:** NeuroCom Data Range: 60-69  
 Post Test Comment

## APPENDIX G

### PARKINSON'S DISEASE POPULATION RAW DATA

#	Age	UPDRS	BBS	SOT											ADT		LOS				
				comp	1	2	3	4	5	6	SOM	VIS	VEST	PREF	Toe Up	Toe Down	RT	MVL	EPE	MXE	DCL
26	72	9	54	77	93	92.33	88.67	84	63.67	62.33	99.28	90.32	68.46	96.79	60	57	1.78	3.5	47	80	81
27	78	14	48	75	91	89.67	90.67	83.33	50.33	67.33	98.54	91.57	55.31	112.86	123	91	1.55	2.3	63	72	77
28	74	11	43	68	91.67	89	83	77.67	61.33	33.67	97.09	84.73	66.9	77.61	48	48	2.1	2.6	51	68	55
29	77			60	94	93.67	90.67	77	28	23.33	99.65	81.91	29.79	93.7	41	60	2.55	2.9	43	57	64
30	78	10	52	73	94.33	91	92.67	73.33	60	51	96.47	77.74	63.61	95.15	88	66	2.26	2.8	57	73	66
31	76	16	49	69	92.33	84.33	85.33	74	61	44.33	91.34	80.15	66.07	89.22	outlier	71	1.94	1.6	44	54	61
32	59	16	51	73	93.33	89.33	92	84.67	47.67	54.33	95.71	90.72	51.08	106.81	60	54	1.2	2.9	55	70	65
33	75	15	44	74	94.33	92.33	90	77.67	56.67	58	97.88	82.34	60.08	99.33	117	85	2.31	1.8	39	61	70
34	80	12	50	66	96.33	86.67	94	65.33	39.33	47	89.97	67.82	40.83	111.9	38	50	2.57	1.5	44	56	68
35	76	19	43	52	94.33	91	84.33	82	16.67	0	96.47	86.93	17.67	78.32	61	104	outlier	0.5	19	27	NM
36	70	25	37	35.83	92.33	0	64.67	35.67	0	22.33	outlier	38.63	0	outlier	67	91	1.64	2.5	46	75	76
37	75	10	46	72	94.67	85	87.67	86.67	40.67	60	89.79	91.55	42.96	117.51	73	57	1.34	2.5	50	57	53
38	76	15	44	78	93	89.67	90	86.67	65.33	59	96.42	93.19	70.25	96.13	95	63	1.17	2	27	46	55
39	63	16	51	75	92	92	89.33	72.67	62.67	65	100	78.99	68.12	99.78	56	43	1.85	1.9	65	77	77
40	62	14	54	79	96.33	89	89	89.67	68.33	59.33	92.39	93.09	70.93	94.28	75	49	1.99	1.5	47	62	75
41	69	10	49	77	97	93	92	86.33	52.67	65	95.88	89	54.3	107.78	67	61	1.42	1.4	62	71	80
42	76	17	41	73	94	90.33	91.67	89.33	46.67	50	96.1	95.03	49.65	103.41	51	59	1.35	1.7	39	66	71
43	60	7	51	59	94	93.67	83.33	64.67	25.67	41	99.65	68.8	27.31	104.18	66	42	1.47	1.4	57	75	76
44	65	13	53	83	93.67	91.33	94	85.33	71	77	97.5	91.1	75.8	105.34	80	80	1.13	2.5	56	78	77
45	68	16	42	43	94.33	86	85.67	0	34.33	19	91.17	outlier	36.39	86.99	86	68	1.93	1.6	43	59	64
46	79	14	32	69	92.33	91	90.33	73	33.67	62	98.56	79.06	36.47	122.19	56	85	1.16	1.9	39	59	67
47	81	16	38	63	94.33	93.67	93.33	38.67	46.67	50.67	99.3	40.99	49.48	102.61	outlier	45	1.94	1.2	33	40	49
48	69	16	50	55	92.67	86.67	80.67	59	37	19.33	93.53	63.67	39.93	80.86	53	52	1.94	0.8	32	42	76
49	76	15	50	66	93.67	81	84.33	86	17.67	63.33	86.47	91.81	18.86	149.65	109	83	1.26	3.4	67	84	74
50	81	19	47	76	92	85.33	82.33	82	71	62.33	92.75	89.13	77.17	92.54	41	40	2.19	1.7	55	64	67
51	80	12	51	80	94.33	92	91.33	88.67	65.33	66.33	97.53	94	69.26	100.21	40	42	0.86	4.8	65	80	76

fall = 0

fall = 200 (outlier)

NM="not measureable"

#	Age	UPDRS	BBS	SOT										ADT		LOS					
				comp	1	2	3	4	5	6	SOM	VIS	VEST	PREF	Toe Up	Toe Down	RT	MVL	EPE	MXE	DCL
1	60	15	41	66	93	82.33	87	86	23.67	52.33	88.53	92.47	25.45	131.44	outlier	36	1.54	1.7	45	55	65
2	81	14	42	60	92	87.67	84.33	69	38	29.33	95.29	75	41.3	90.44	69	48	outlier	0.6	29	32	NM
3	81			43	93	90	85.33	54.33	0	0	96.77	58.42	0	94.81	71	76	1.1	3	45	58	52
4	65	22	53	82	96.33	91	92	90	71.67	69	94.47	93.43	74.4	98.97	45	32	1.7	1.5	62	76	88
5	74	28	35	71	95	91.33	85.33	83.67	49.67	46.67	96.14	88.07	52.28	93.62	94	64	outlier	1.6	31	34	NM
6	61	13	53	74	90	94.33	89.67	85	52.67	59	104.81	94.44	58.52	101.14	53	61	1.61	3.1	85	102	81
7	79	17	53	80	95	94	93.67	85.33	65.33	65.33	98.95	89.82	68.77	99.79	61	53	1.65	2.1	50	66	64
8	67	8	54	84	94	83.67	88	89.33	74	80	89.01	95.03	78.72	106.55	51	36	1.51	2.2	49	59	62
9	59	33	45	59	85.33	88.33	90.67	70.33	0	56	103.52	82.42	0	outlier	42	28	1.43	2	79	84	81
10	73	29	38	54	96	90.67	93.33	81	6	8.67	94.45	84.38	6.25	105.51	94	83	2.58	0.8	30	35	77
11	81	26	35	68	95	90.33	92.67	73.67	38.67	52.33	95.08	77.55	40.71	112.4	79	54	2.06	0.8	34	38	57
12	63	11	50	55	95	92.33	93.33	85	0	15	97.19	89.47	0	117.33	70	52	1.21	2.6	44	73	80
13	66	19	44	72	94.33	90.33	92	73.67	43.67	64	95.76	78.1	46.29	116.42	40	36	0.83	1.9	59	76	72
14	66			73	95	89	91.67	78.67	52	55	93.68	82.81	54.74	104.02	36	37	1.44	1.8	56	74	79
15	82	32	42	47	91.33	81	75	68.67	2	18.33	88.69	75.19	2.19	112.45	82	61	1.46	3.1	55	71	74
16	73	10	48	82	96.67	92.67	93	90.67	65.33	68.33	95.86	93.79	67.58	102.11	53	43	2.2	0.9	62	69	88
17	72	28	41	70	95.33	92.67	94	86.33	36	47.33	97.21	90.56	37.76	109.84	58	41	outlier	0.4	12	19	NM
18	69	9	52	72	90.67	87.67	84	81.67	60.33	52.67	96.69	90.07	66.54	92.34	53	44	2.38	1.5	40	51	70
19	74	28	37	70	92.33	88.33	85.67	77.67	62.33	40.33	95.67	84.12	67.51	83.63	87	87	0.91	2.5	27	37	45
20	81	21	31	33	86.67	78.67	66	34.67	0	0	90.77	40	0	83.89	76	81	NM	NM	NM	NM	NM
21	75	14	39	55	95.33	91.67	89.67	62.33	24.67	16.33	96.16	65.38	25.88	91.11	43	50	2.3	1.1	35	42	71
22	71	30	49	47	88.33	83.67	80.67	61	0	20	94.72	69.06	0	120.32	79	47	2.33	1.5	48	55	60
23	61	11	55	75	95.67	89	82.33	86.33	45.33	76	93.03	90.24	47.38	117.87	68	43	0.36	5.5	79	88	74
24	76	11	43	70	95.67	94.67	89.67	82.67	48.33	44	98.95	86.41	50.52	93.48	84	56	2.12	1.4	43	53	75
25	76	18	51	58	84.67	88.67	87.67	83.67	42	0	104.72	98.82	49.6	67.09	46	43	outlier	2.1	33	48	NM

fall = 0

fall = 200 (outlier)

NM="not measureable"

## APPENDIX H

### NEUROCOM HEALTHY POPULATION MEANS AND STANDARD DEVIATIONS DIVIDED BY AGE GROUPS

**Table H.1. Sensory Organization Test NeuroCom Healthy Population Means and Standard Deviations**

Sensory Organization Test (SOT)	Ages 60 - 69		Ages 70 - 79	
	Mean	SD	Mean	SD
Composite	77.59	5.99	72.85	5.43
Somatosensory	97.2	3.2	95.1	7.9
Visual	90.9	5	85	6.6
Vestibular	69.7	9.3	67.3	10.4
Preferential	98.4	6.5	94.9	14.4

**Table H.2. Adaptation Test NeuroCom Healthy Population Means and Standard Deviations**

Adaptation Test (ADT)	Ages 60 - 69		Ages 70 - 79	
	Mean	SD	Mean	SD
Toes Up (5 <sup>th</sup> trial)	59.56	14.10	65.93	15.10
Toes Down (5 <sup>th</sup> trial)	49.13	15.87	59.93	23.46

**Table H.3. Limits of Stability Test NeuroCom Healthy Population Means and Standard Deviations**

Limits of Stability (LOS)	Ages 60 - 69		Ages 70 - 79	
	Mean	SD	Mean	SD
Reaction Time (RT)	0.9	0.36	1.05	0.37
Movement Velocity (MVL)	4.0	1.1	3.5	1.6
End Point Excursion (EPE)	72.0	9.1	69.0	14.5
Maximum Excursion (MXE)	87.6	9.6	86.8	17.4
Directional Control (DCL)	70.7	7.9	73.5	8.3



## APPENDIX I

ADJUSTED NEUROCOM HEALTHY POPULATION MEAN AND SD  
DATA

Test	60 - 69			70 - 79			$\Sigma(\Sigma(Y_i - Y)^2)$	$\Sigma(Y_i)$	60-79		
	y	s2	n2	y	s2	n2			Y	S2	N2
SOT Composite	77.589	5.995	26	72.85	5.431	29	1724.382	4129.964	75.09	5.651	55
SOT Somatosensory	97.167	3.2	26	95.883	7.9	29	2003.48	5306.949	96.49	6.091	55
SOT Visual	90.933	5	26	86.809	6.6	29	1844.68	4881.719	88.759	5.845	55
SOT Vestibular	69.653	9.3	26	68.875	10.4	29	5190.73	3808.353	69.243	9.804	55
SOT Preferential	98.305	6.5	26	95.796	14.4	29	6862.33	5334.014	96.982	11.273	55
ADT Toes Up (5th)	59.556	14.104	26	65.929	15.104	29	11360.733	3460.397	62.916	14.505	55
ADT Toes Down (5th)	49.13	15.873	26	59.929	23.457	29	21705.267	3015.321	54.824	20.049	55
LOS Reaction Time	0.9	0.36	26	1.05	0.37	29	7.073	53.85	0.979	0.362	55
LOS Movement Velocity	4	1.1	26	3.5	1.6	29	101.93	205.5	3.736	1.374	55
LOS Endpoint Excursion	72	9.1	26	69	14.5	29	7957.25	3873	70.418	12.139	55
LOS Maximum Excursion	87.6	9.6	26	86.8	17.4	29	10781.28	4794.8	87.178	14.13	55
LOS Directional Control	70.7	7.9	26	73.5	8.3	29	3489.17	3969.7	72.176	8.038	55

APPENDIX J

HISTOGRAMS & P-P PLOTS OF PD POPULATION

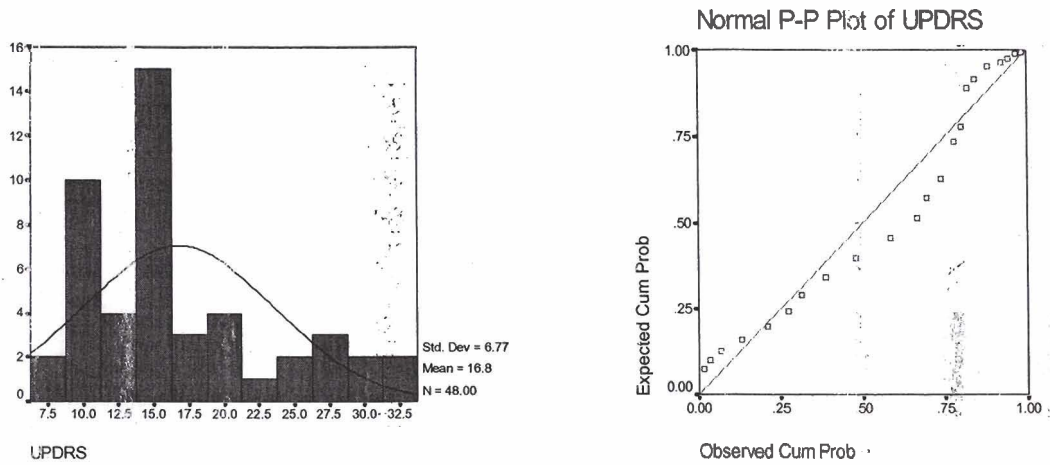

Figure J.1. UPDRS Histogram & P-P Plot of PD Data.

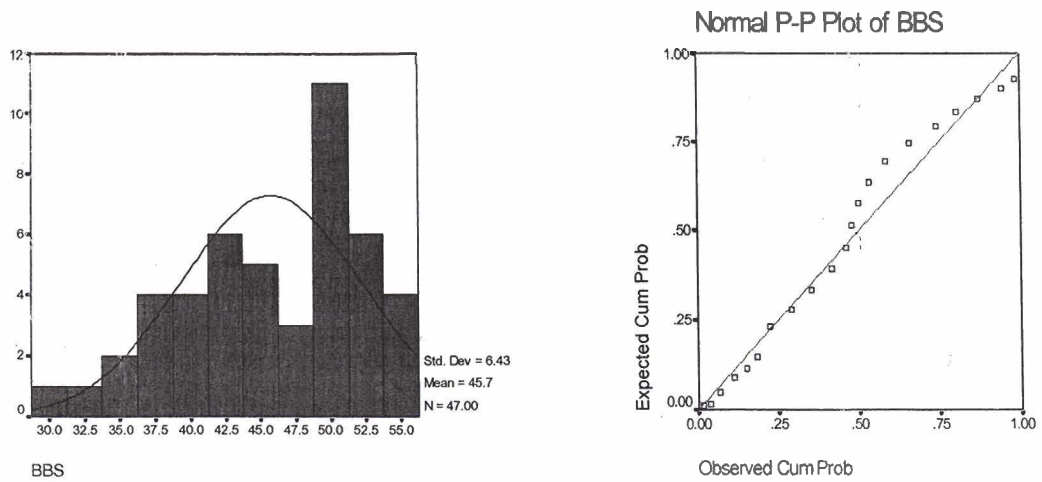

Figure J.2. BBS Histogram & P-P Plot of PD Data.

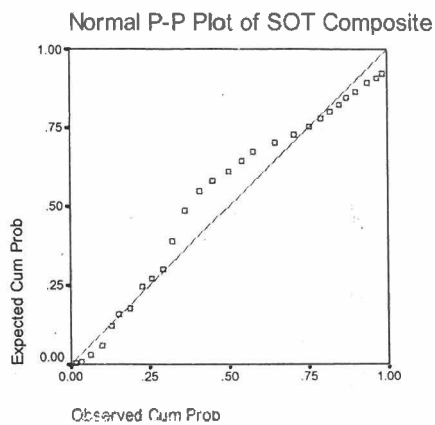
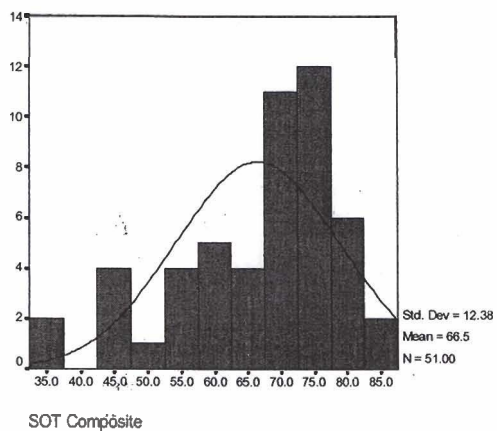

Figure J.3. SOT Composite Histogram & P-P Plot of PD Data.

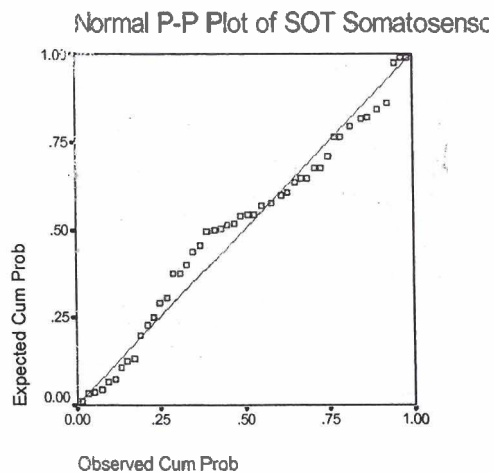
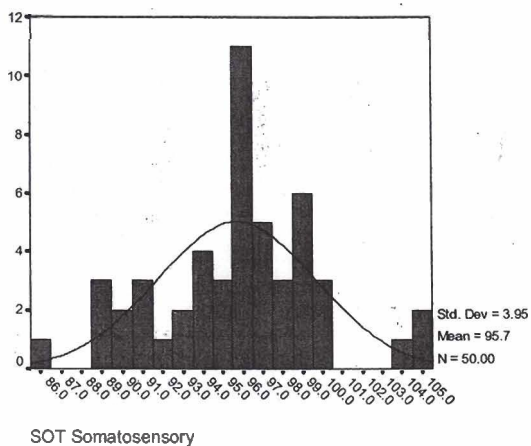

Figure J.4. SOT Somatosensory Histogram & P-P Plot of PD Data.

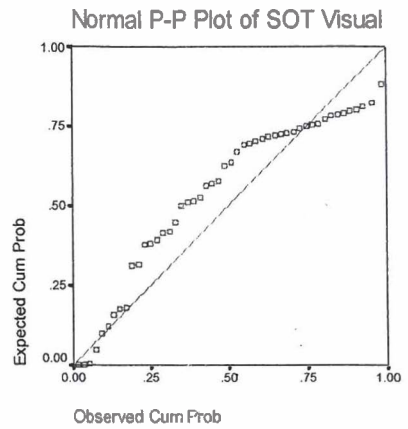
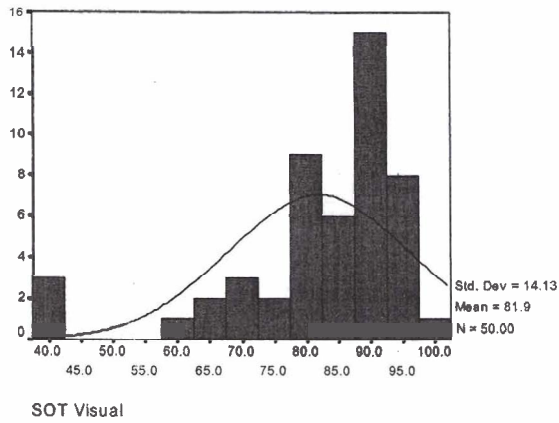

Figure J.5. SOT Visual Histogram & P-P Plot of PD Data.

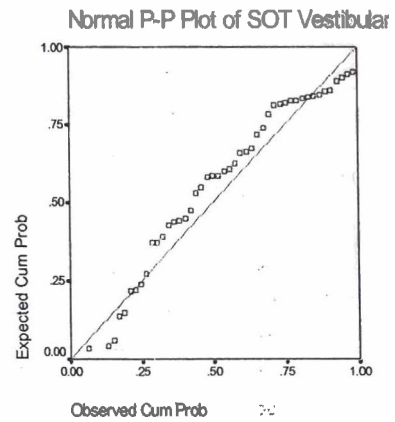
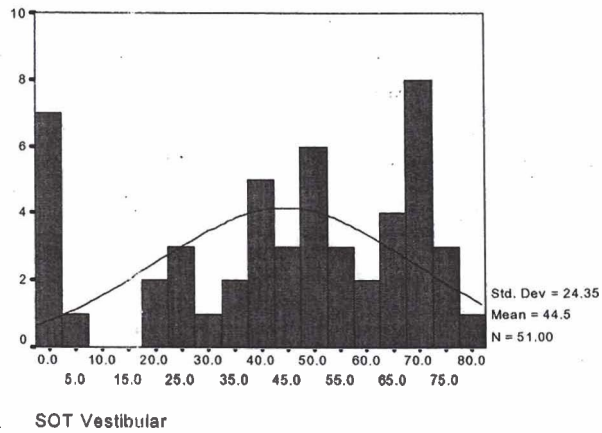

Figure J.6. SOT Vestibular Histogram & P-P Plot of PD Data.

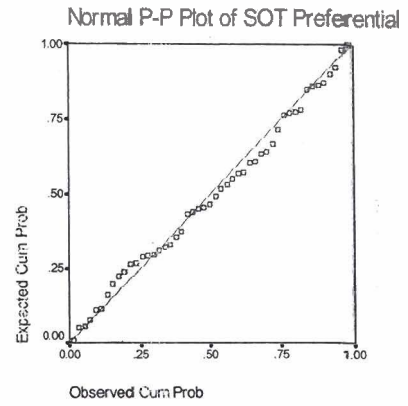
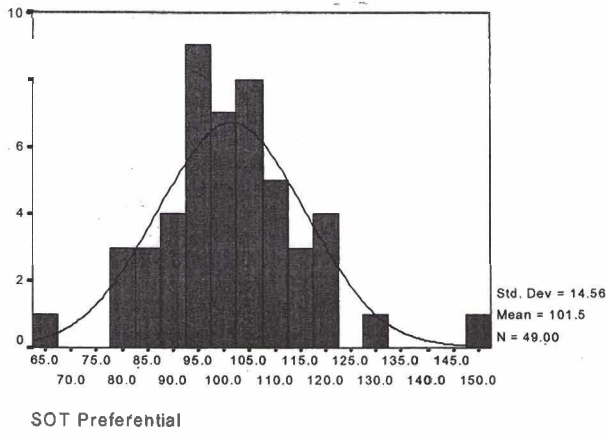

Figure J.7. SOT Preferential Histogram & P-P Plot of PD Data.

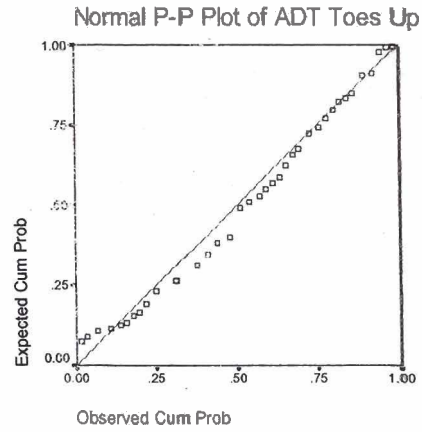
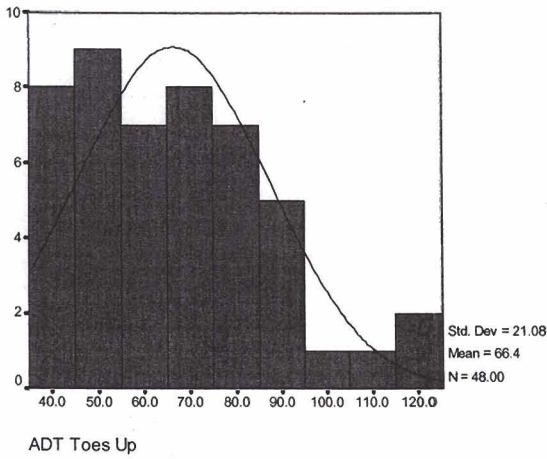

Figure J.8. ADT Toes UP (5<sup>th</sup> Attempt) Histogram & P-P Plot of PD Data.

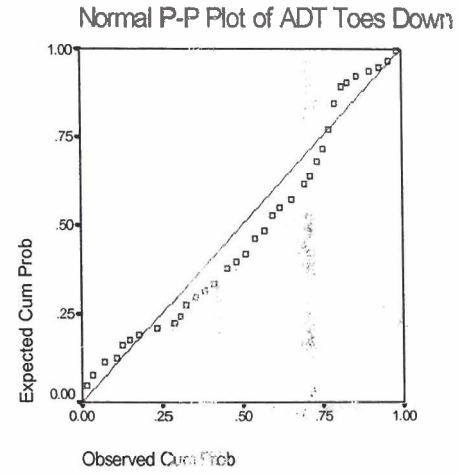
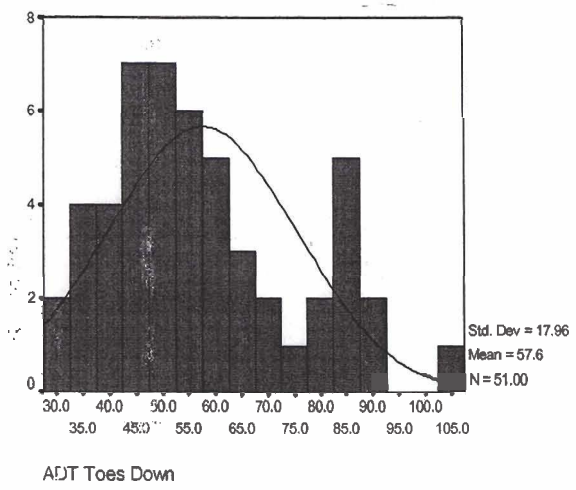

Figure J.9. ADT Toes DOWN (5<sup>th</sup> Attempt) Histogram & P-P Plot of PD Data.

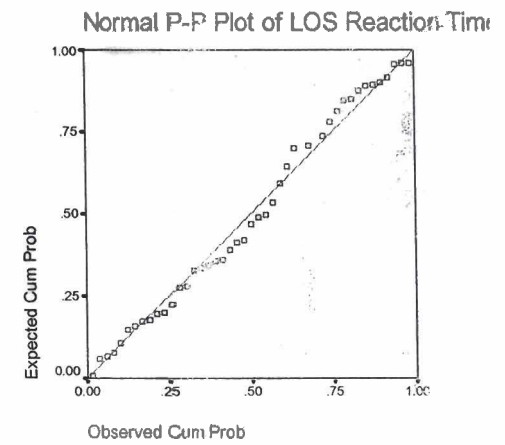
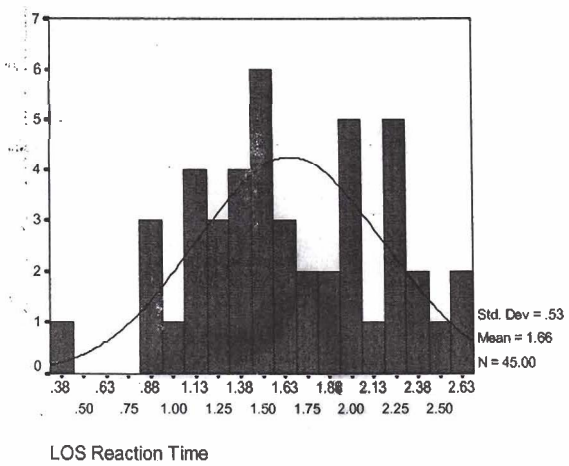

Figure J.10. LOS Reaction Time Histogram & P-P Plot of PD Data.

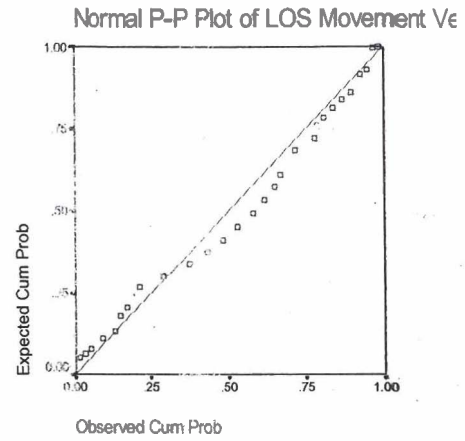
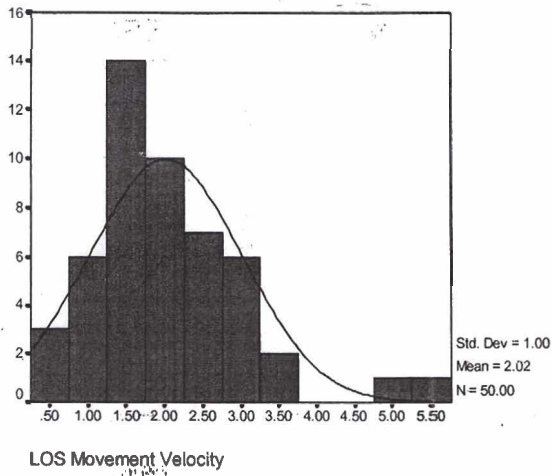

Figure J.11. LOS Movement Velocity Histogram & P-P Plot of PD Data.

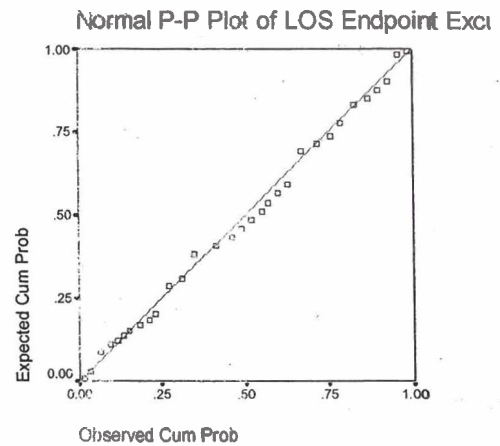
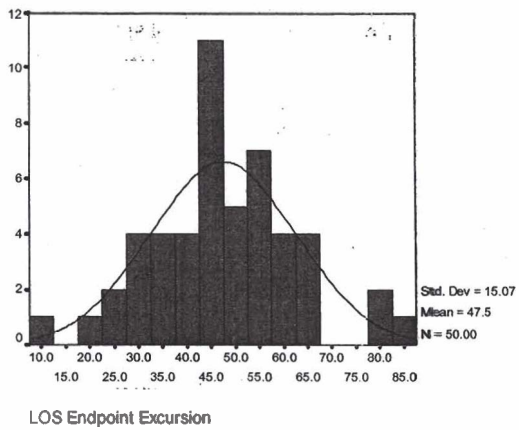

Figure J.12. LOS Endpoint Excursion Histogram & P-P Plot of PD Data.

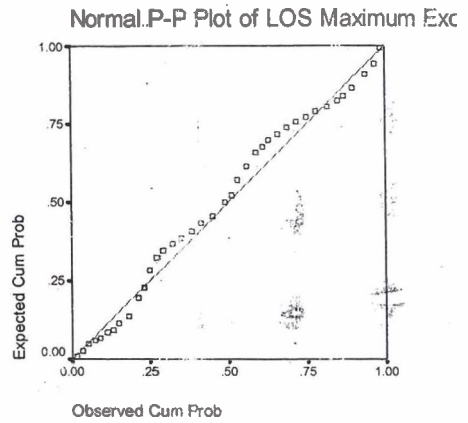
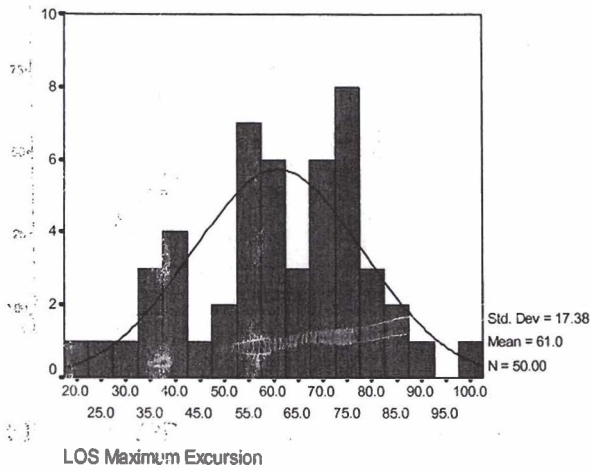

Figure J.13. LOS Maximum Excursion Histogram & P-P Plot of PD Data.

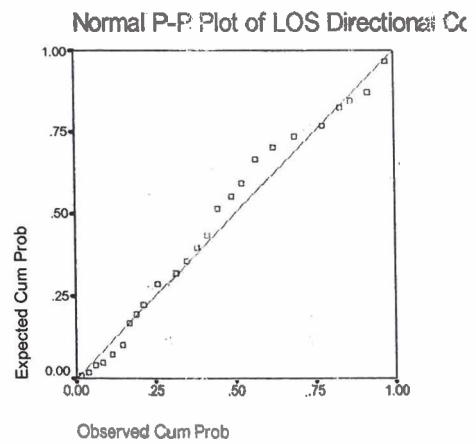
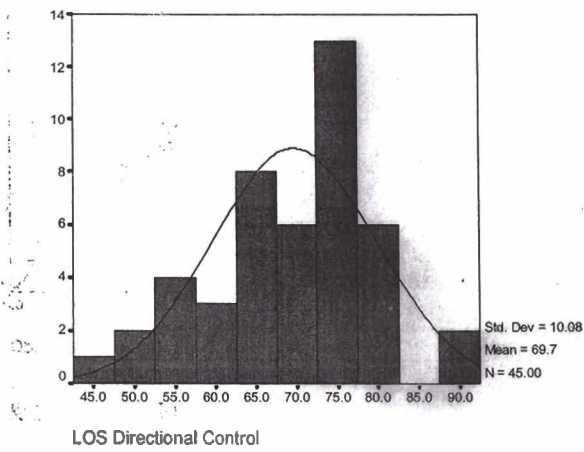

Figure J.14. LOS Directional Control Histogram & P-P Plot of PD Data.



## APPENDIX K

## SAMPLE CALCULATIONS

All sample calculations use the SOT Composite test score as the example.

K.1. Adjusting NeuroCom Healthy Population Calculation.

NeuroCom Healthy Population (AGES 60 – 69):

$$y_a = 77.59$$

$$s_a = 5.99$$

$$n_a = 26$$

NeuroCom Healthy Population (AGES 70 – 79):

$$y_b = 72.85$$

$$s_b = 5.43$$

$$n_b = 29$$

$$\bar{Y} = \frac{\sum Y_i}{n} = \frac{(\bar{Y}_a * n_a) + (\bar{Y}_b * n_b)}{n_a + n_b} = \frac{(77.59 * 26) + (72.85 * 29)}{26 + 29}$$

$$\bar{Y} = 75.09$$

$$S_2 = \sqrt{\frac{s_a^2(n_a - 1) + s_b^2(n_b - 1)}{(n_a + n_b) - 1}} = \sqrt{\frac{5.995^2(26 - 1) + 5.431^2(29 - 1)}{(26 + 29) - 1}}$$

$$S_2 = 5.65$$

Adjusted NeuroCom Healthy Population (AGES 60 – 79):

$$\begin{aligned}\bar{Y} &= 75.09 \\ S_2 &= 5.65 \\ n &= 55\end{aligned}$$

### K.2. Skewness and Kurtosis Value Calculation.

$$\alpha = 0.05$$

Hypothesis: Ho: Test Statistic falls within Skewness Critical Interval

Ha: Test Statistic does not fall within Skewness Critical Interval

$$\text{Skewness Value} = \text{TestStatistic} \pm 1.96 \times \text{StandardDeviation} = (-0.935) \pm (1.96) \times (0.333)$$

$$\text{Skewness Value} = (-0.282, -1.588)$$

$$\text{Kurtosis Value} = \text{TestStatistic} \pm 1.96 \times \text{StandardDeviation} = (0.302) \pm (1.96) \times (0.656)$$

$$\text{Kurtosis Value} = (1.588, -2.81)$$

### K.3. Equal Variance Calculation: F-test.

$$\alpha = 0.05$$

Hypothesis: Ho:  $\sigma_1 = \sigma_2$

Ha:  $\sigma_1 \neq \sigma_2$

Parkinson's Disease Population:

$$S_1 = 12.38$$

$$m = 51$$

NeuroCom Healthy Population (AGES 60 – 79):

$$S_2 = 5.65$$

$$n = 55$$

$$F = \frac{S_1^2}{S_2^2} = \frac{(12.38)^2}{(5.65)^2}$$

$$F = 4.797$$

$F_{obs} (4.797) > F_{(1-\alpha/2, m-1, n_1-1)} (1.5787)$ . Therefore, we reject  $H_0$ . The sample variance of the PD population is not equal to that of the healthy population,  $\alpha = 0.05$ .

#### K.4. Significant Difference Population Means Calculation: t-test.

$$\alpha = 0.05$$

$$\text{Hypothesis: } H_0: \bar{X} \geq \bar{Y}$$

$$H_a: \bar{X} < \bar{Y}$$

Parkinson's Disease Population:

$$\bar{X} = 66.49$$

$$S_1 = 12.38$$

$$m = 51$$

NeuroCom Healthy Population (AGES 60 – 79):

$$\bar{Y} = 75.09$$

$$S_2 = 5.65$$

$$n = 55$$

$$T_{obs} = \frac{\bar{X} - \bar{Y}}{\sqrt{\frac{S_1^2}{m} + \frac{S_2^2}{n}}} = \frac{66.49 - 75.09}{\sqrt{\frac{12.38^2}{51} + \frac{5.65^2}{55}}}$$

$$T_{obs} = -4.542$$

$$df = \frac{\left(\frac{S_1^2}{m} + \frac{S_2^2}{n}\right)^2}{\left(\frac{S_1^2}{m}\right)^2 \left(\frac{1}{m-1}\right) + \left(\frac{S_2^2}{n}\right)^2 \left(\frac{1}{n-1}\right)} = \frac{\left(\frac{(12.38)^2}{51} + \frac{(5.68)^2}{55}\right)^2}{\left(\frac{(12.38)^2}{51}\right)^2 \left(\frac{1}{51-1}\right) + \left(\frac{(5.68)^2}{55}\right)^2 \left(\frac{1}{55-1}\right)}$$

$$df = 68.8$$

$T_{obs}(-4.542) < T_{df=68.8}(-1.6672)$ . There for, we reject  $H_0$ . The mean of the PD population is determined to be significantly less than the mean of NeuroCom's healthy population,  $\alpha = 0.05$ .

## VITA

Theresa Erin McGuirk was born on June 8, 1980, in Alexandria, Virginia, and is an American citizen. She graduated from West Potomac High School, Alexandria, Virginia in 1998. She received her Bachelor of Science in Mechanical Engineering from Virginia Polytechnic Institute and State University, Blacksburg, Virginia in 2002. While pursuing a master's degree, she worked as a biomedical engineer and contributed to several research projects in the Parkinson's Disease Research Education and Clinical Center (PADRECC) at the Hunter Holmes McGuire VA Medical Center. She received a Master of Science in Biomedical Engineering from Virginia Commonwealth University, Richmond, Virginia in 2005.